

**915021**

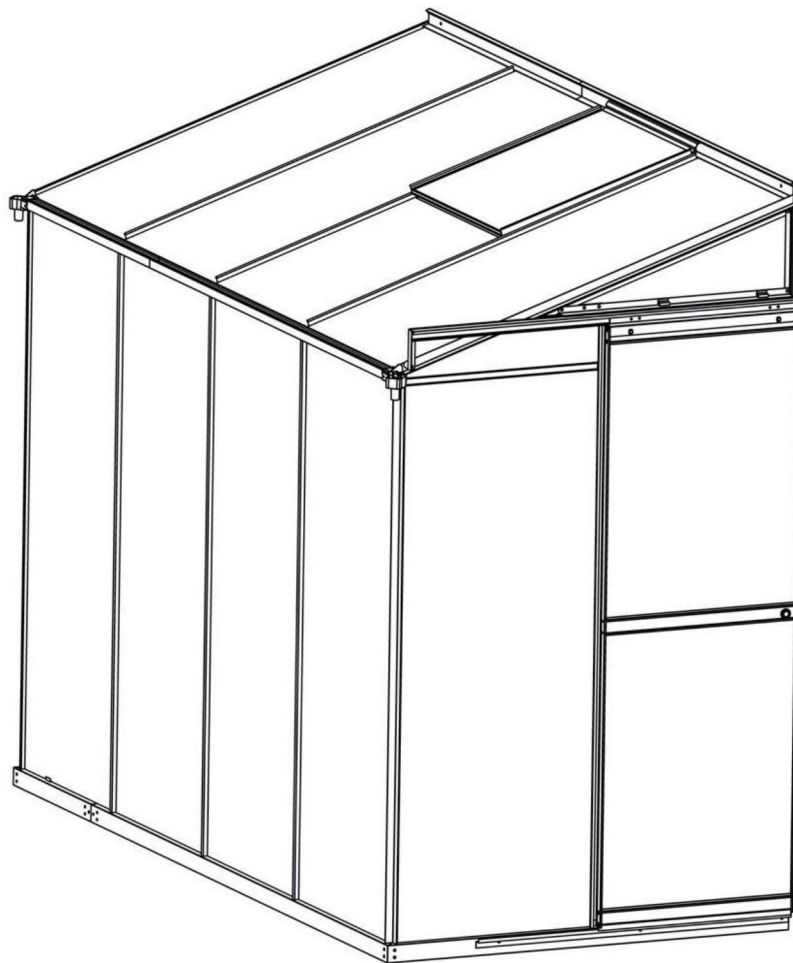

**Návod na montáž skleníka**

## PRED MONTÁŽOU

Pred začatím montáže si dôkladne preštudujte tieto pokyny. Výrobok vyžaduje pre montáž minimálne 2 osoby. Vyhradte si na montáž dostatok času, odporúčame aspoň pol dňa. Skleník musí byť umiestnený a upevnený na rovnom povrchu. Zvoľte slnečné miesto ďaleko od previsnutých stromov. Pokiaľ pripevňujete skleník priamo na pevný betónový základ, použite predvrtané otvory v dodanom kovovom základe.

Dodržiujte montážne kroky v presnom poradí. Vyberte všetky komponenty a diely z balenia. Pred inštaláciou skontrolujte všetky súčasti a diely. Všetky diely sú označené číslom, pri kontrole tieto čísla porovnajte s dodaným zoznamom dielov. Diely by mali byť položené v dosahu ruky. Uchovávajte všetky malé diely (skrutky a pod.) v miske či inej nádobe, aby sa nestratili. Upozorňujeme, že tento produkt používa viacboké profily. V dôsledku toho niektoré otvory v profiloch nie sú použité počas montáže.

## ODPORÚČANIA

Pre jednoduchšie nastavenie polohy jednotlivých dielov počas montáže skrutky pevne neťahujte. Všetky skrutky by mali byť pevne utiahnuté až v poslednom kroku montáže. Na rám, kde sa spoje dotýkajú a kde sa rám dotýka krytu, odporúčame nalepiť alebo pridať penu/gumu. Predĺži to životnosť krytu.

## BEZPEČNOSTNÉ POKYNY

Pred montážou skleníka sa uistite, že v zemi nie sú skryté rúrky alebo káble. Dôrazne odporúčame pri montáži použiť pracovné rukavice, pevnú obuv, ochranu hlavy (napr. bezpečnostnú prilbu) a ochranné okuliare. Konštrukciu skleníka nijako neupravujte. Počas inštalácie na rám nevesajte žiadne závažia, ani diely. Nepokúšajte sa zostaviť skleník za veterného alebo daždivého počasia. Neumiestňujte skleník na miesto vystavené nadmernému vetru. Nezostavujte skleník v dosahu elektrického vedenia. Pri montáži neposúvajte skleník. Udržujte deti mimo oblasti montáže. Nepokúšajte sa zostaviť skleník, ak ste unavení, užili ste drogy, alkohol alebo ak mávate závraty. Pri používaní rebríka alebo elektrického náradia dodržujte bezpečnostné pokyny výrobcu. Horúce predmety, ako sú nedávno použité grily, horáky a pod., nesmú byť uložené v blízkosti skleníka. Neručíme za škody alebo zranenia vzniknuté nesprávnou inštaláciou, neoprávnenými úpravami alebo extrémnym počasím. Táto stavba nie je určená na bývanie.









## PO MONTÁŽI



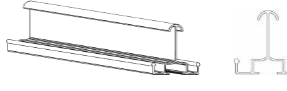
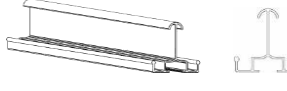
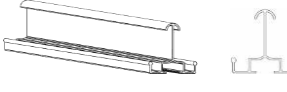





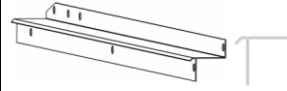

Pravidelne prechádzajte okolo skleníka a dôkladne ho kontrolujte, aby ste sa uistili, že všetky časti sú správne upevnené a celá konštrukcia je v poriadku. Skontrolujte všetky skrutky a matice aj všetky spoje, aby ste sa presvedčili, že sú v správnej polohe. Dôrazne odporúčame ihneď odstraňovať napadaný sneh. Nenechávajte sneh ležať na streche cez noc. Na všetkých stranách vždy udržiajte voľný priestor v šírke cca 1 metra. Nenechajte sneh hromadiť po stranách skleníka. Inak by tlak z bokov tlačil smerom dovnútra a mohlo by dôjsť k zrúteniu skleníka. **Strecha unesie tlak snehu max. 40 kg/m<sup>2</sup>.**

## ÚDRŽBA



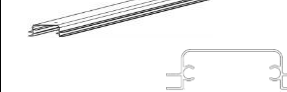
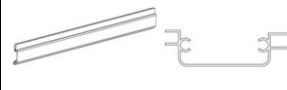







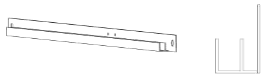

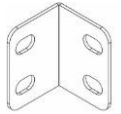







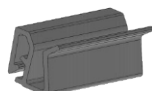

Na čistenie skleníka používajte vhodné čistiace prostriedky, ktoré potom opláchnite vodou. Na čistenie nepoužívajte acetón, abrazívne čističe alebo iné špeciálne prípravky.

## II. Príslušenstvo & diely (1)











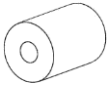

kód		Ks
L1 .4K		2
L2 .4K		1
L3 .4K		1
L4 .4K		3
L5 .4K		1
L6 .4K		3
L7 .48K		1
L8 .48K		1
L9 .48K		1
L10 .48K		1
L11 .4K		1
L12 .4K		1



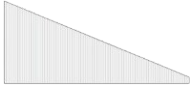







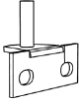

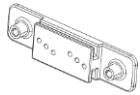
kód		Ks
L13 .4K		2
L14.4K		1
L15 .4K		1
L16 .4K		1
L17 .4K		1
L18 .4K		1
L19 .4K		1
L20 .4K		1
L21 .4K		1
L22.4K		1
L23L.4K		1
L23R.4K		1

## II. Príslušenstvo & diely (2)

kód		Ks	C de		Ks
L24 . 4K		1	B1 . B		1
L25.4K		1	B2 . B		2
L26 . 4K		1	B3 . K		1
L27 . 4K		1	B4 . B		1
L28 . 4K		1	B5 . B		1
L29 . 4K		2	B6 . B		4
L30 . 4K		3	B7 . K		2
R7		13	B8 . K		1
1 . 4L		1	B15 . B		1
2 . 4L		1	R2		1
5 . 48L		1	R3		1
6 . 48L		1	R4		1

## II. Príslušenstvo & diely (3)

kód		Ks
R8		1
P1 . 4L		3
P3 . 4L		4
P4 . 4L		3
P5 . 4L		1
P6 . 4L		1
P7 . 4L		1
P8 . 4L		1
P9 . 4L		2
P10 . 4L		1
P11 . 4L		1
J1		1

kód		Ks
J2		1
J3		1
J4		2
J5		4
J6		120
Y1		91
Y3	M4x14 	5
Y4		4
Y6	ST4,2x9,5 	4
Y7	ST4,8x10 	8
Y9	ST4,8x19 	12
Y10	M6x40 	1



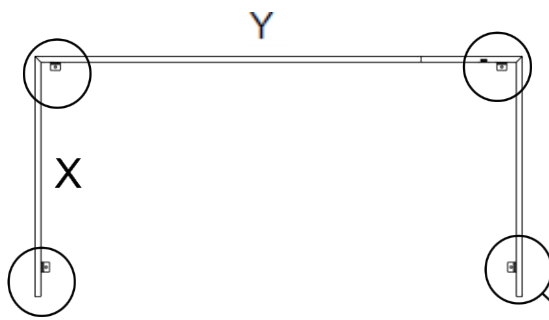

Veľkosť skleníka	Rozmery	
4'x8' (1220 x 2478 mm)	X= 1220 mm	Y=2478 mm

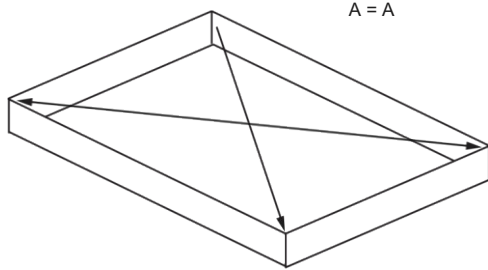

A = A

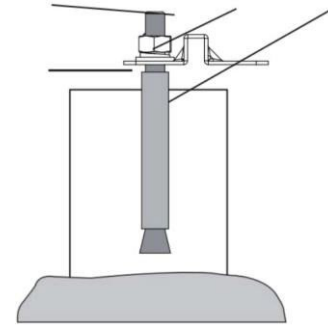
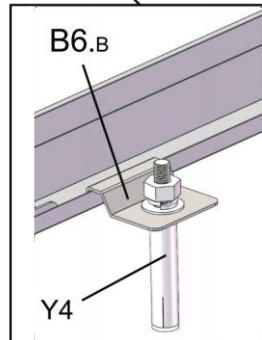

Inštalácia základne

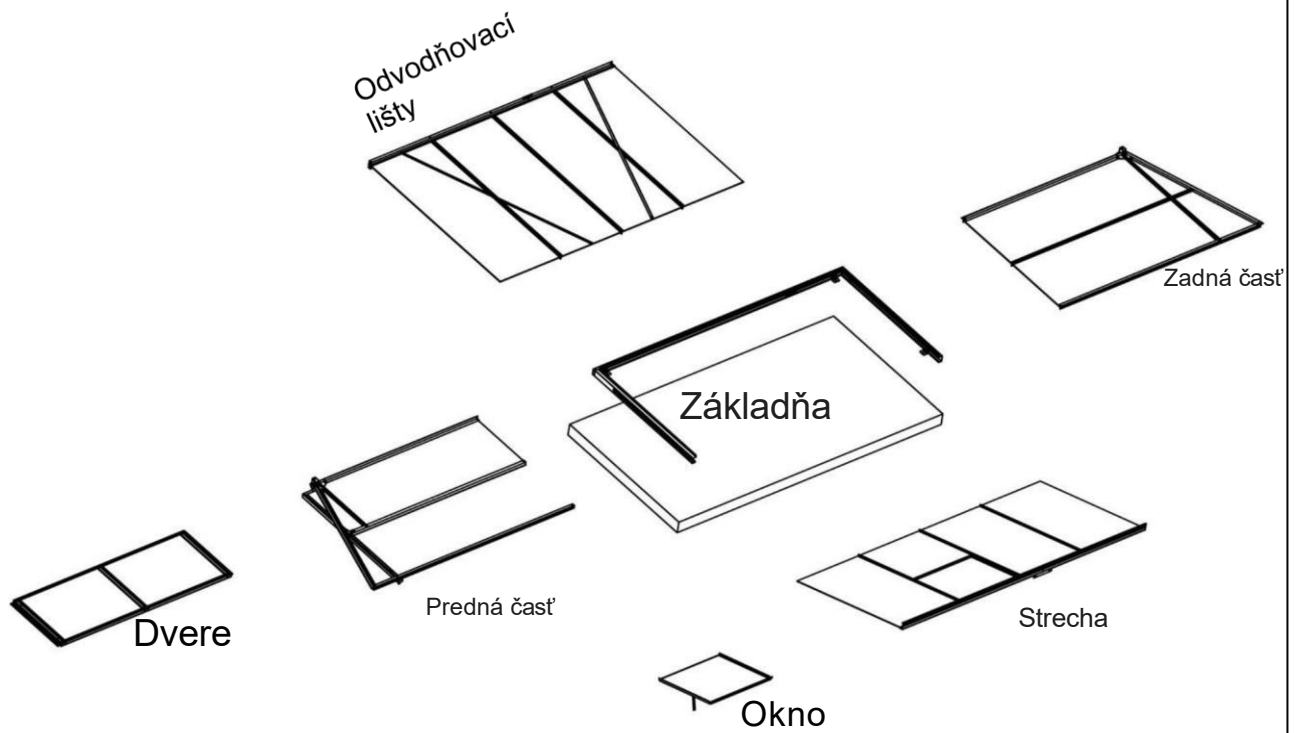

Prehľadný nákras

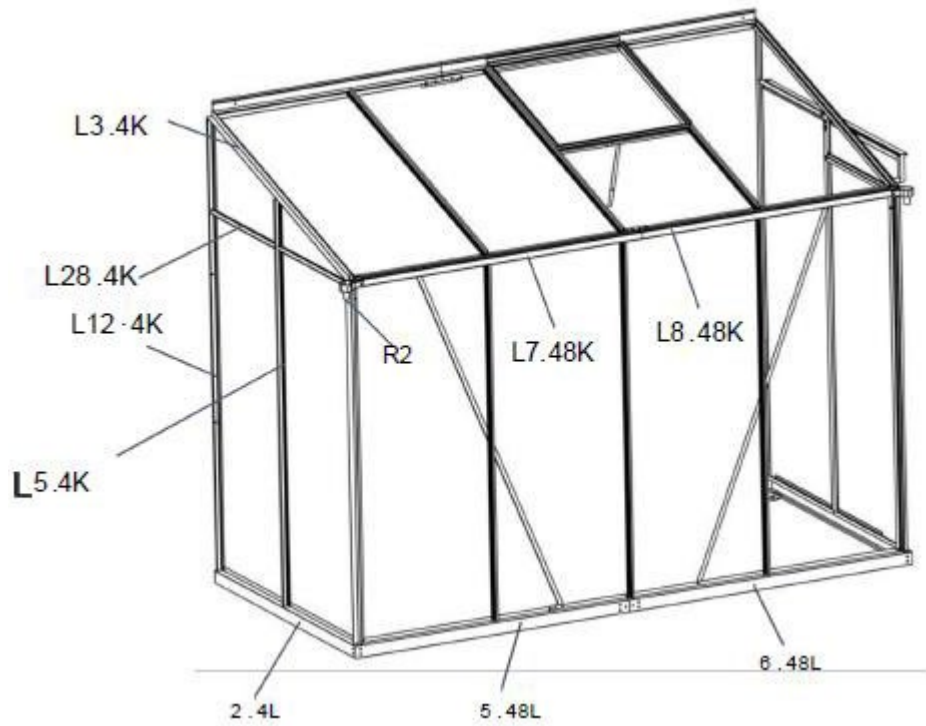
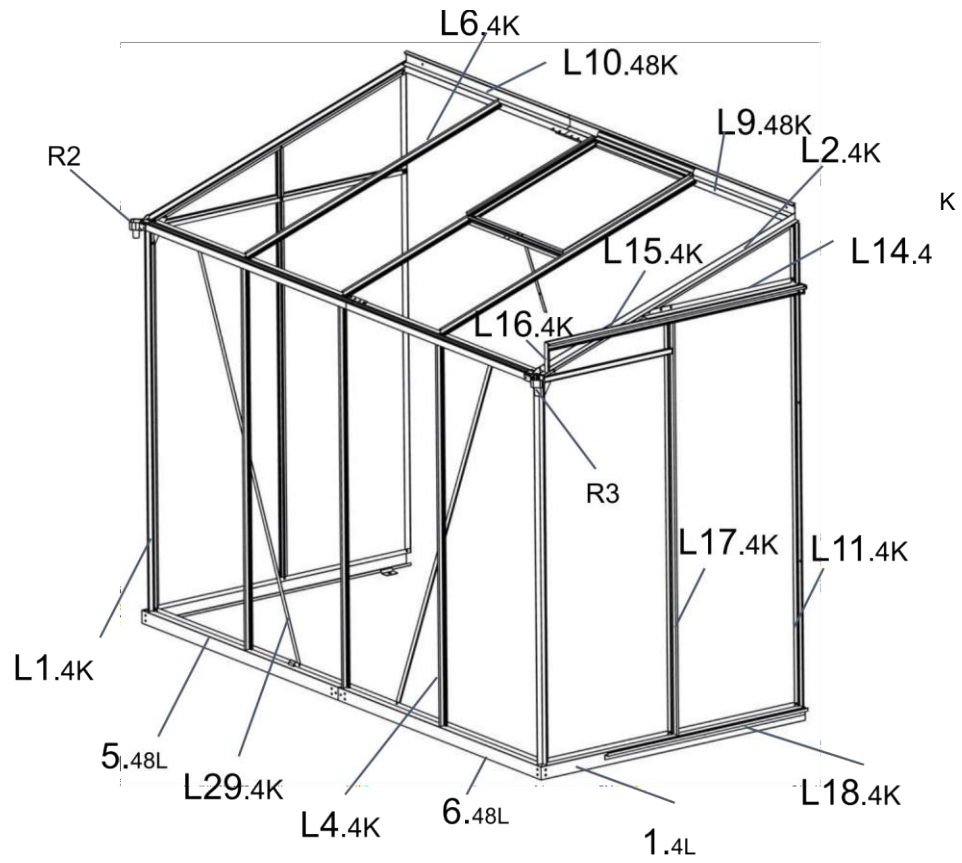

# 1

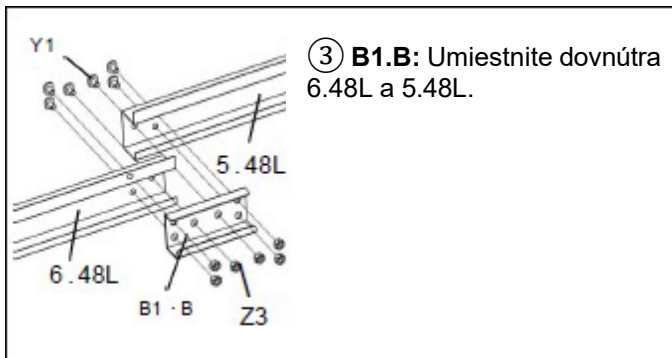
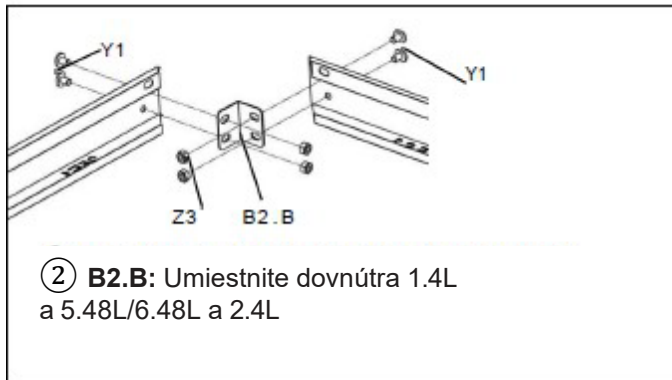
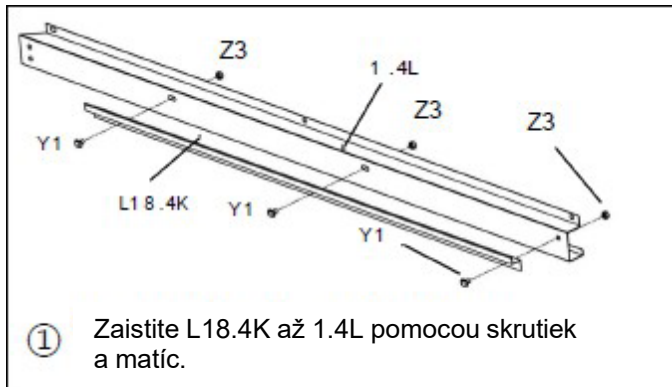
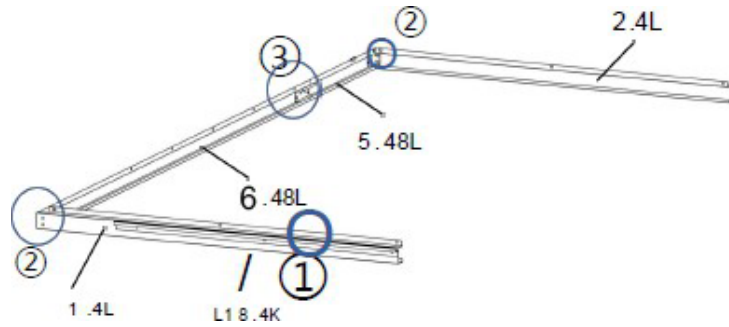

**Poznámka:**

1) Položte diely na zem, ako je znázornené na obrázku v hornej časti tejto stránky. Zostavte voľne pomocou matíc na vnútornej strane konštrukcie.  
 (2) Všetky obrázky sú zobrazené zvnútra skleníka, pokiaľ nie je uvedené inak.

kód		Ks
1.4L		1
2.4L		1
5.48L		1
6.48L		1
Y1		17
Z3		17
B1.B		1
B2.B		2
L18.4K		1

# 2

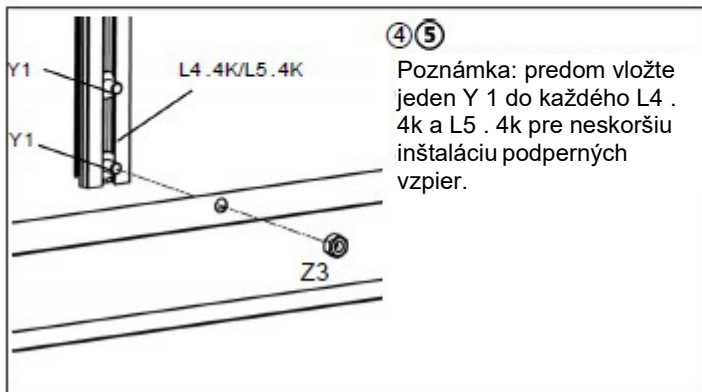
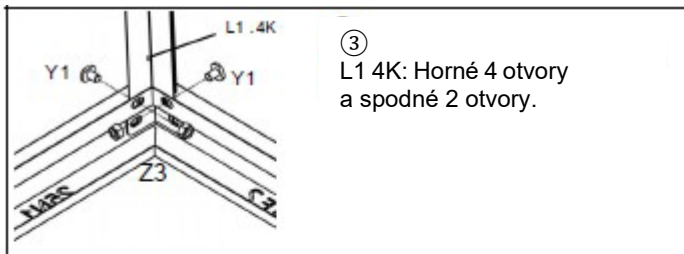
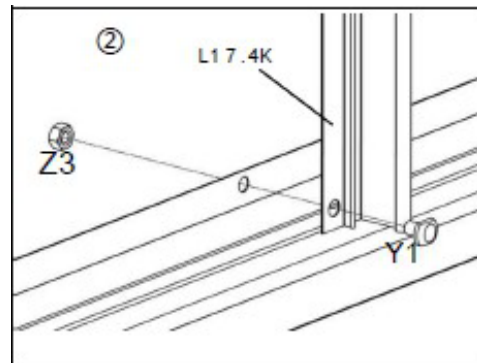
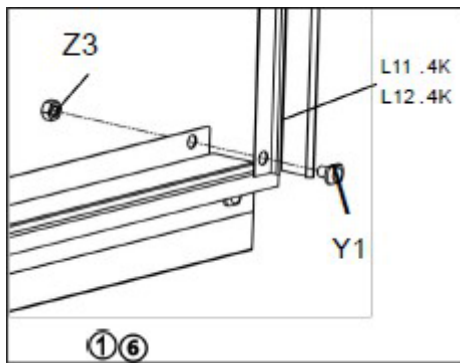
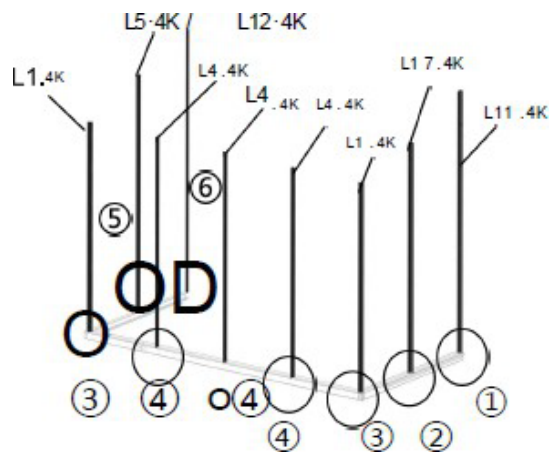

kód		Ks
L1.4K		2
L4.4K		3
L5.4K		1
L11.4K		1
L12.4K		1
L17.4K		1
Y1		15
Z3		11

# 3

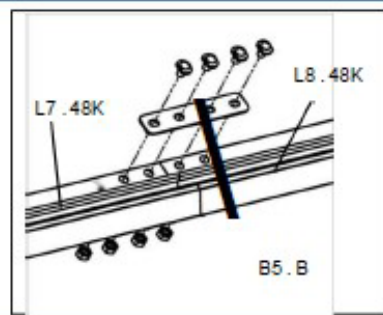
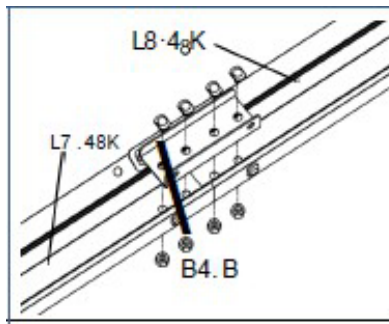
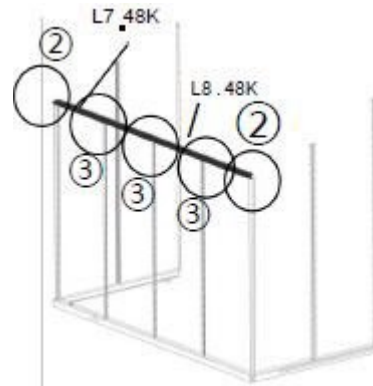

①

Pripojte L7 . 48k a L8 . 48k, ako je znázornené na schéme.

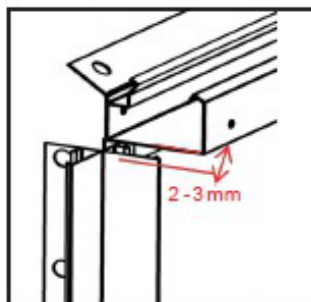
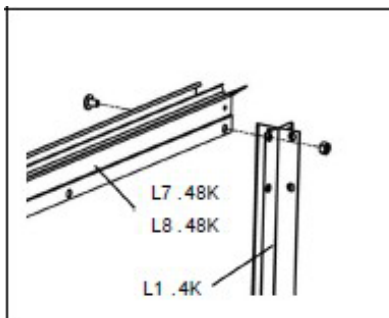

②

Poznámky: Nedoťahujte úplne – ponechajte medzeru 2-3 mm pre neskoršiu inštaláciu odvodňovacích líšt.

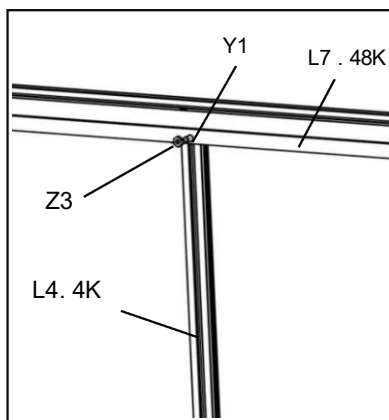

③

Vložte jeden Y1 do drážky L4 . 4K a cez otvory L7. 48k pre upevnenie.

kód		Ks
L7 . 48K		1
L8 . 48K		1
Y1		13
Z3		13
B4 . B		1
B5 . B		1

# 4-1

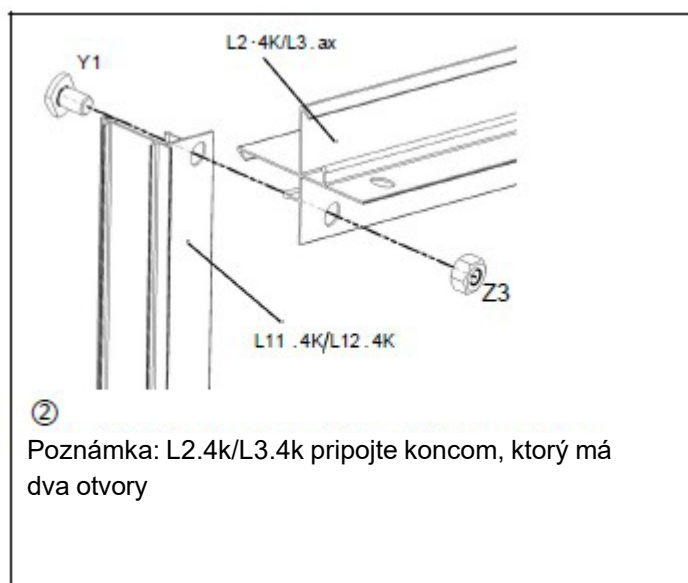
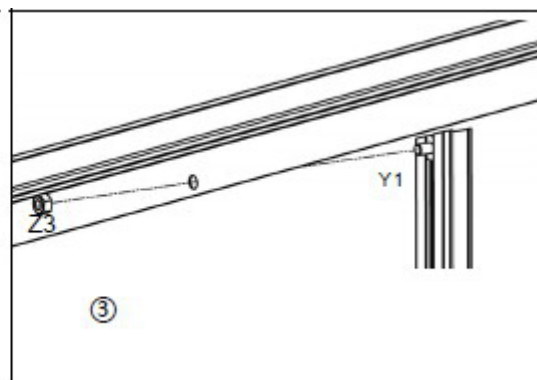
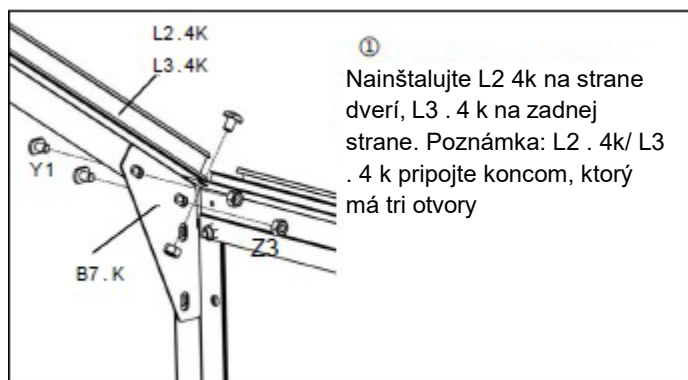
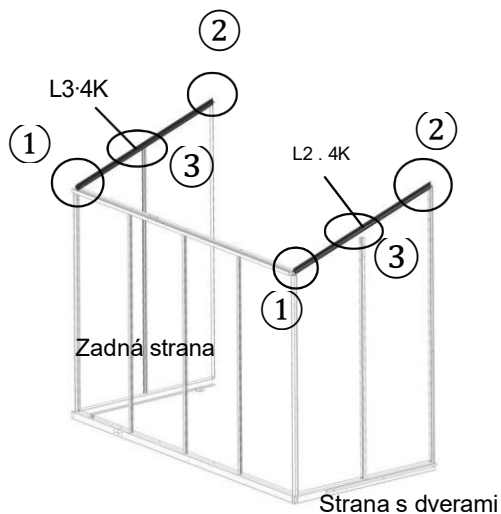

kód		Ks
L2 . 4K		1
L3 . 4K		1
Y1		10
Z3		10
B7 . K		2

# 4-2

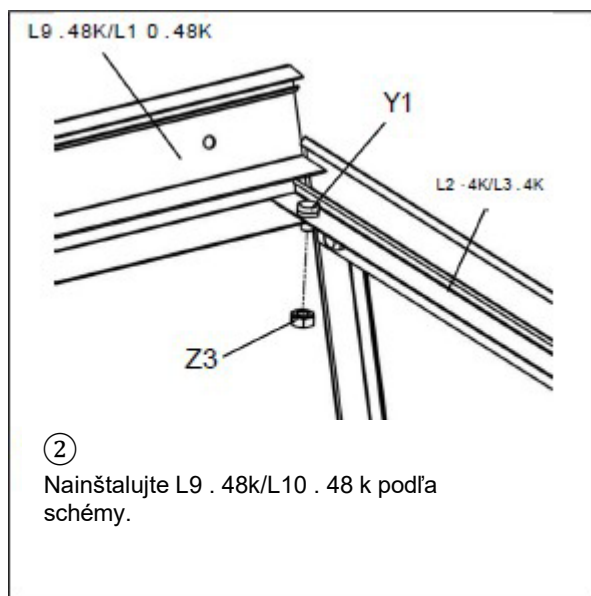
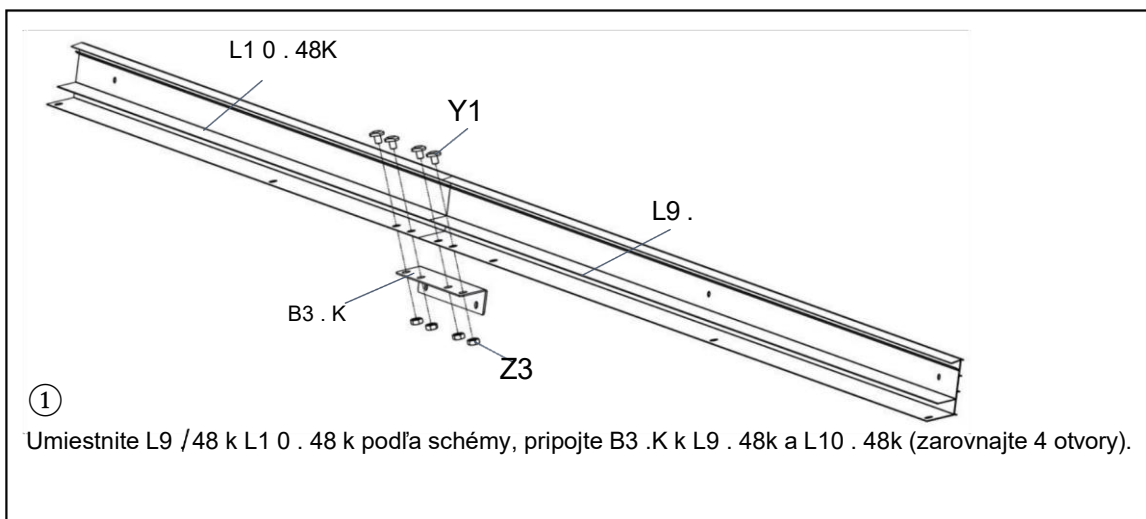
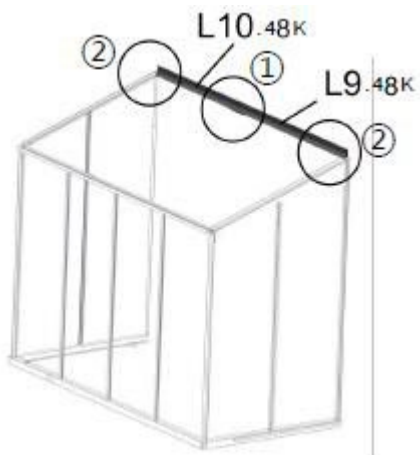

kód		Ks
L9 . 48K		1
L10 . 48K		1
B3 . K		1
Y1		6
Z3		6

# 4-3

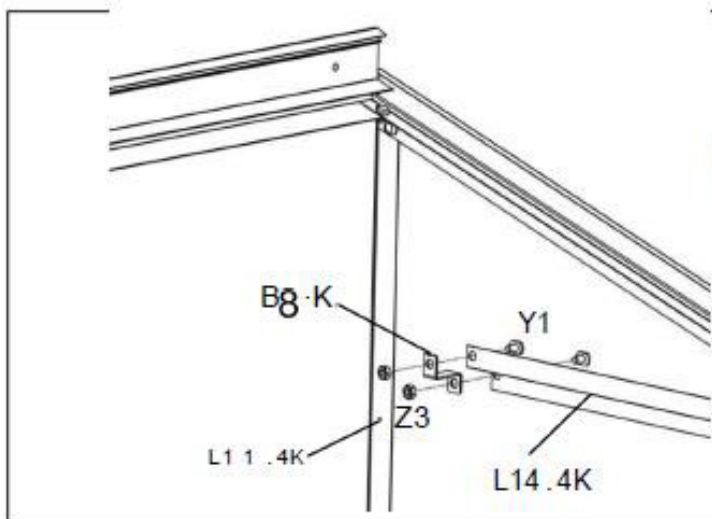
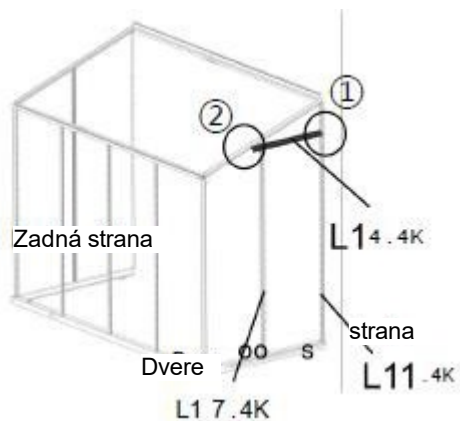



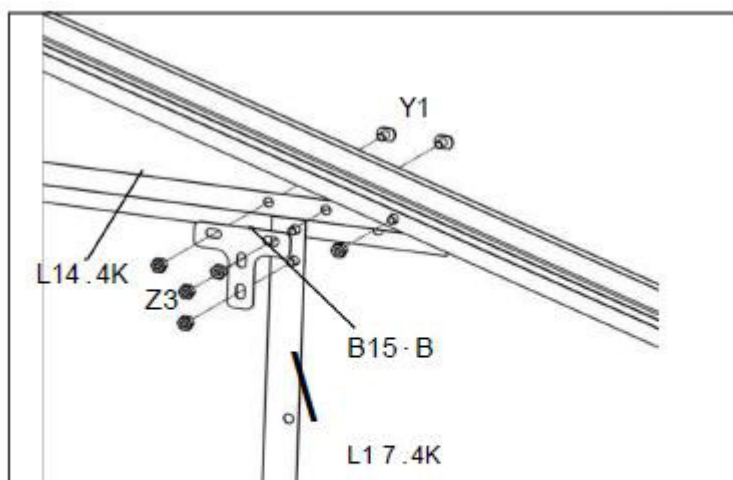

①

Nainštalujte L14.4K, B8.K a L11.4K podľa schémy.



②

Nainštalujte L14.4K, B15.B a L17.4k podľa schémy.

kód		Ks
L14.4K		1
B8.K		1
B15.B		1
Y1		6
Z3		6

# 4-4

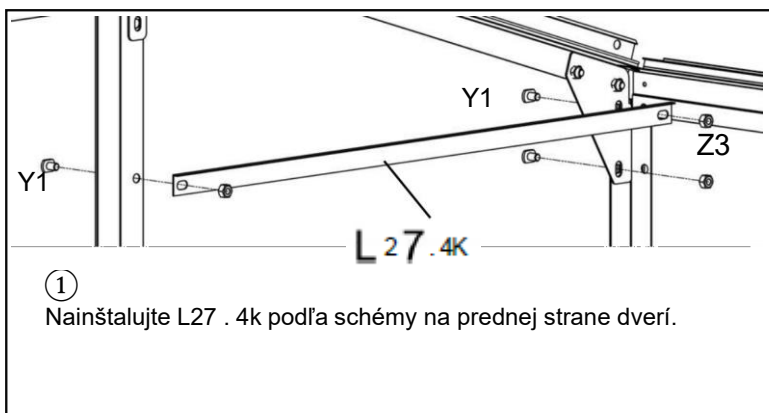
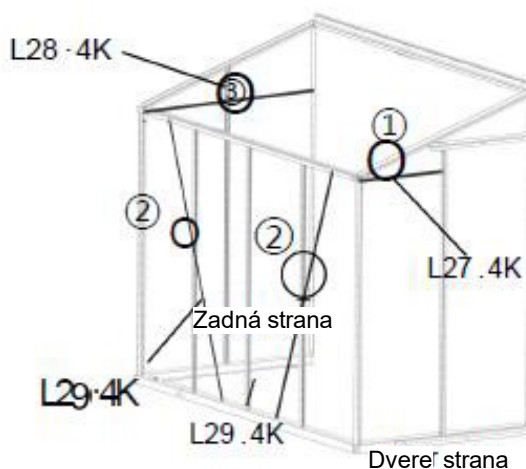

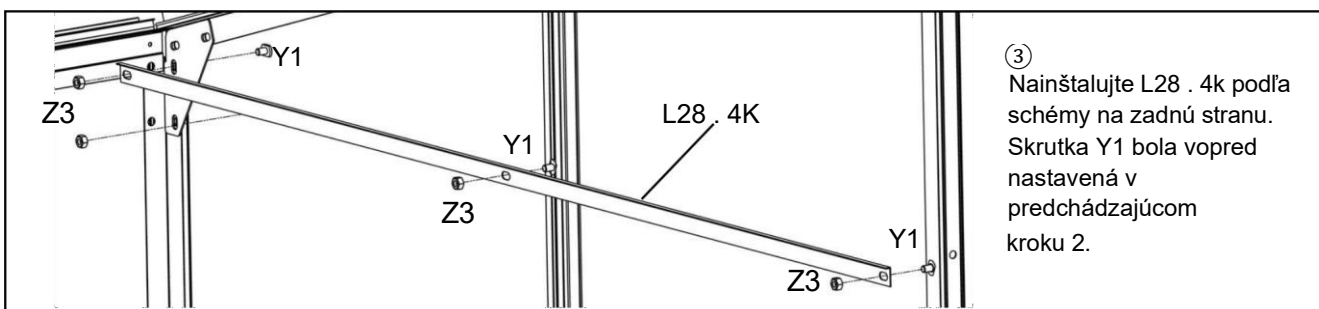
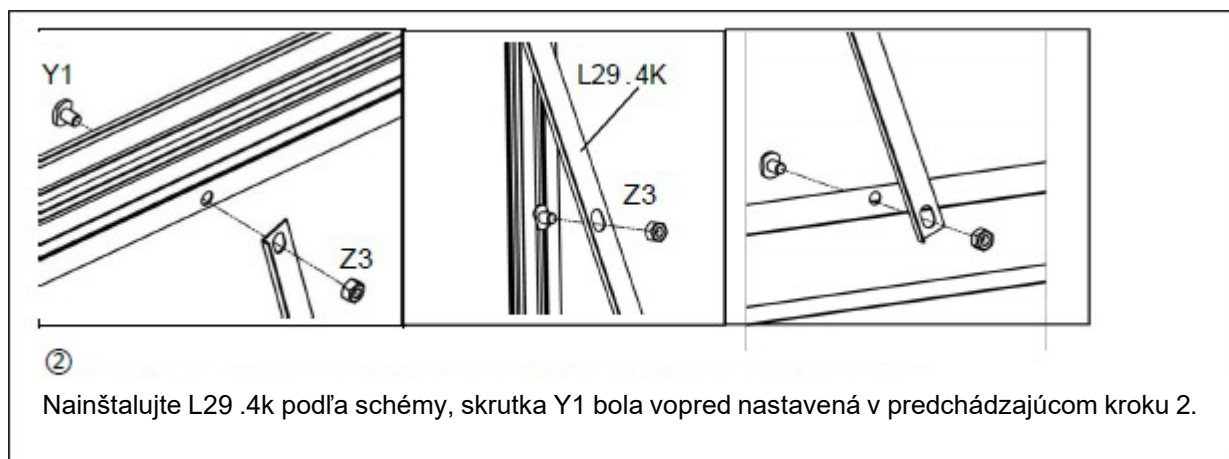

kód		Ks
L27 .4K		1
L28 .4K		1
L29 .4K		2
Y1		11
Z3		13

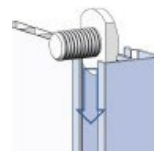
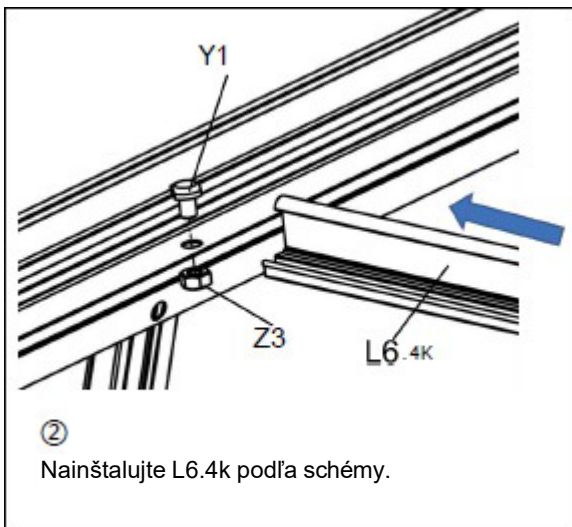
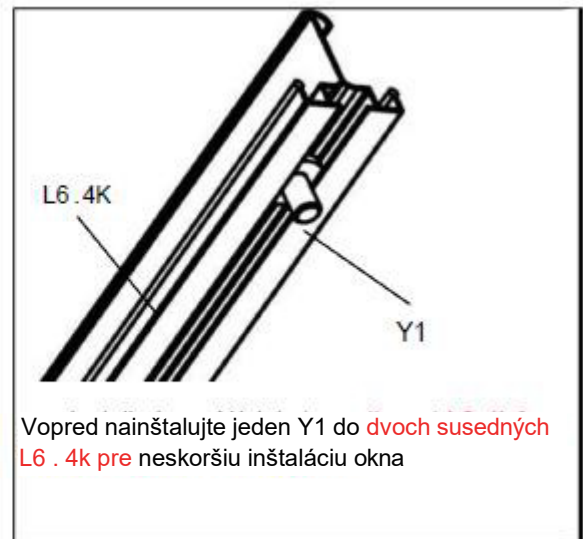
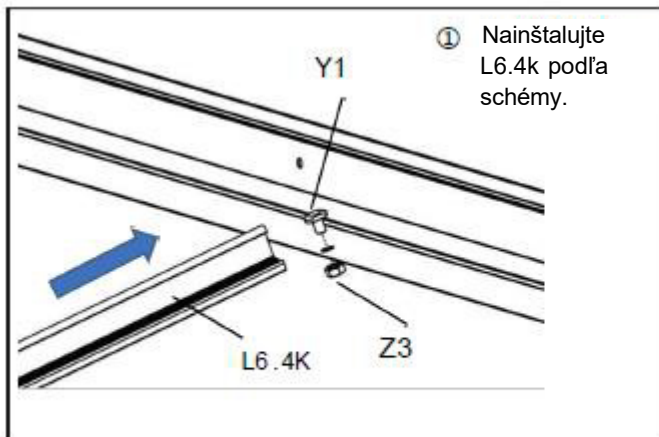
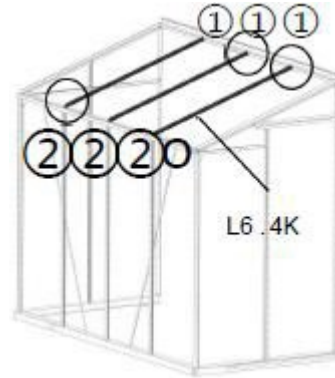
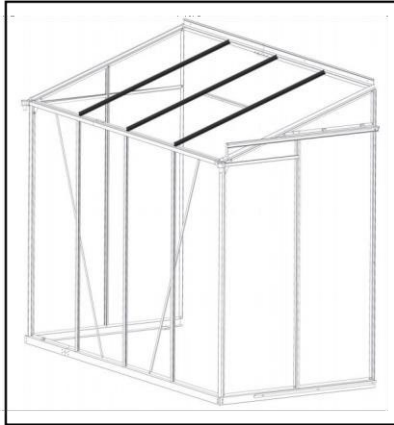

# 5



kód		Ks
L6.4K		3
Y1		8
Z3		6

# 6-1

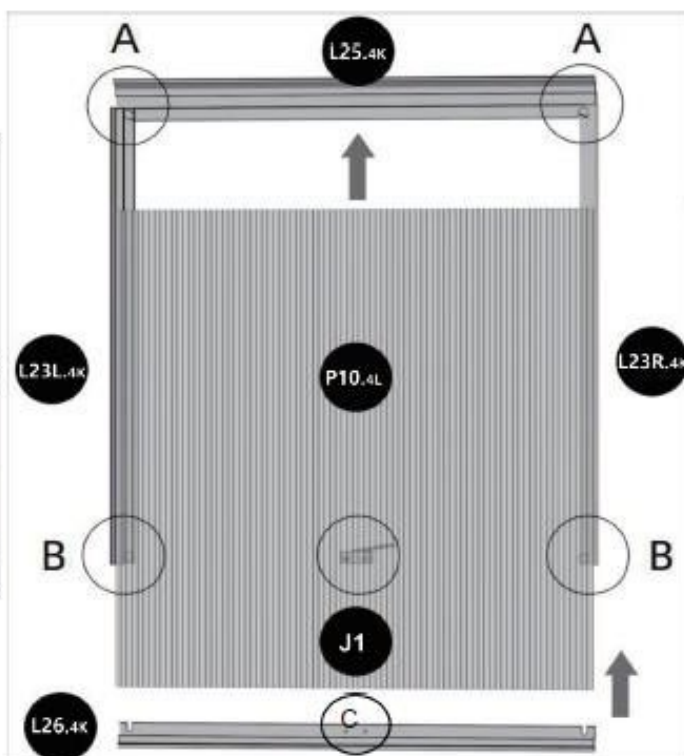
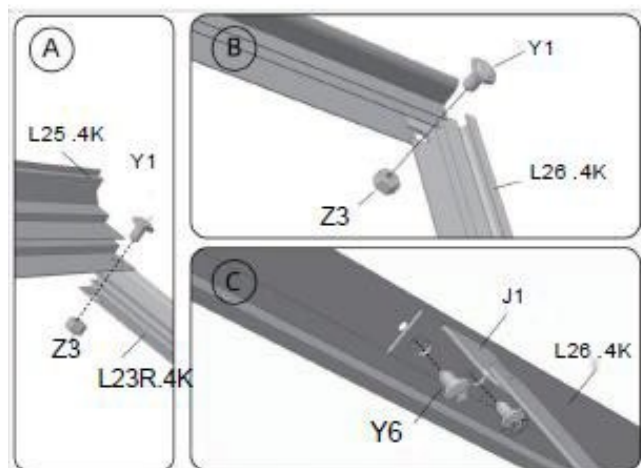

①

1. Všetky diely umiestnite do pozície podľa schémy A, oba konce L25.4K upevnite (neuťahujte).
2. Vložte panel P10.4L do slotu a upevnite oba konce L26.4K podľa schémy B.
3. Otočte okienko na zadnú stranu a nainštalujte J1 podľa schémy C, utiahnite pomocou skrutiek a matic.

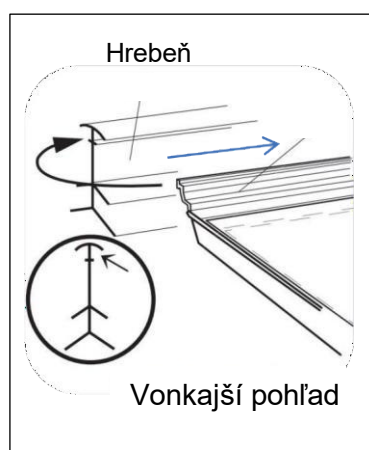

②: Vložte okno do drážky hrebeňa a vsuňte ho zľava alebo sprava do správnej polohy.

kód		Ks
L25 .4K		1
L23L.4K		1
L23R.4K		1
L264K		1
P10 .4L		1
J1		1
Y6		2
Y1		4
Z3		4

# 6-2

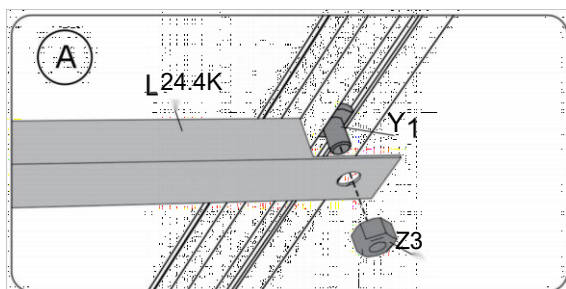
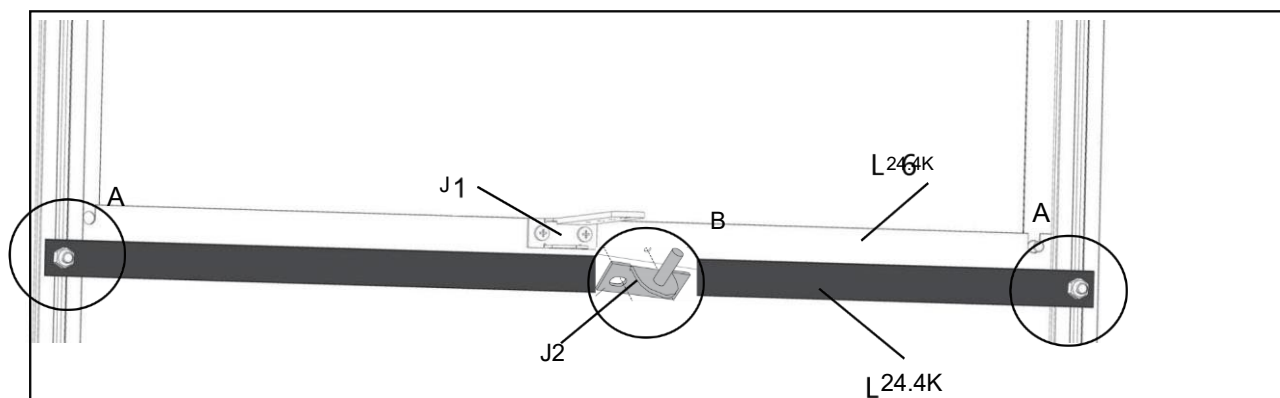
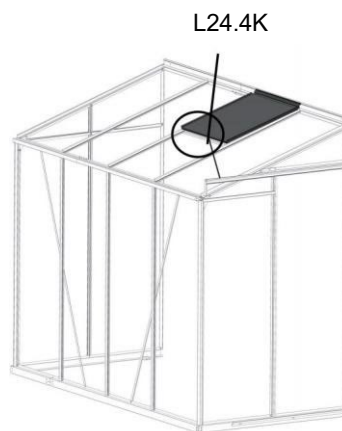
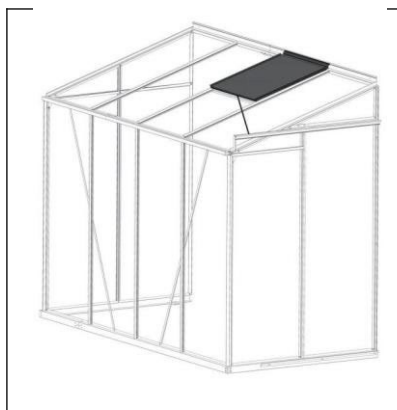

Poznámka:  
Y1 bolo už predom nainštalované v predchádzajúcom kroku 5

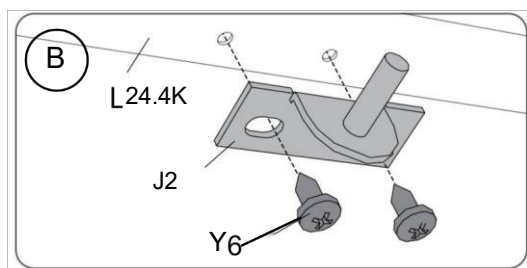

kód		Ks
L24.4K		1
J2		1
Y6		2
Z3		2

1. Zaistíte, aby bolo okno zatvorené, a overte, že L24.4K je zarovnané s L26.4K.
2. Drážka L24.4K by mala byť otočená dole pre neskoršiu inštaláciu polykarbonátových panelov.
3. Nainštalujte J2 na L24.4K s kolíkom smerujúcim nahor, aby pri otvorení okna zapadol do J1.

# 7

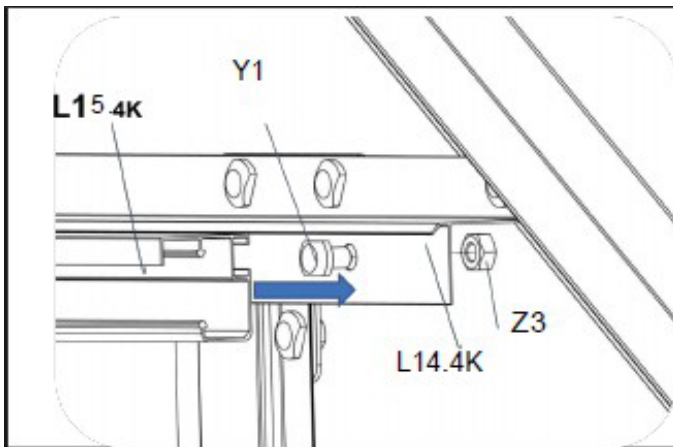
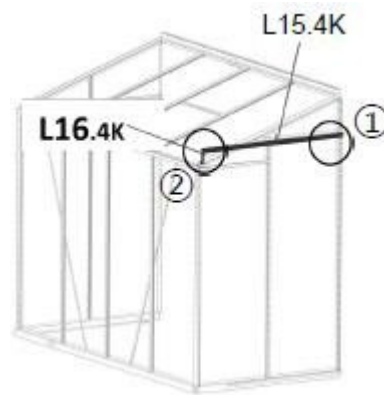
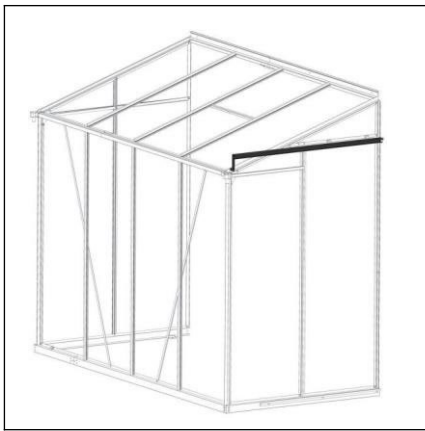

①

Vopred nainštalujte Y1&z3 do L14. 4K, ktoré už bolo vopred nainštalované v kroku 4 (neuťahujte), potom zasunúť drážku L15 .4K do nainštalovaného Y1 na L14 . 4K

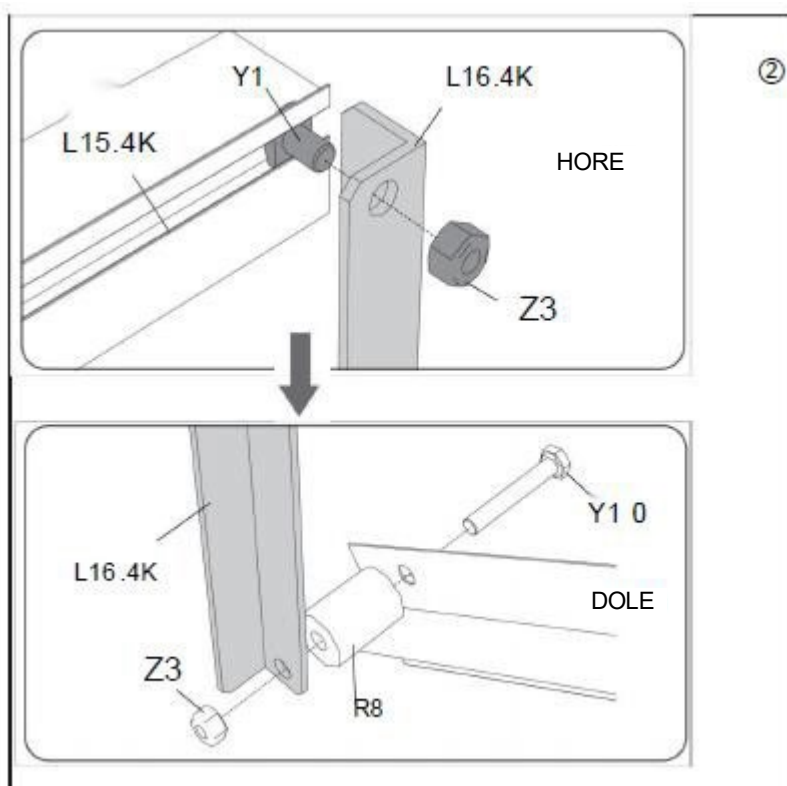

②

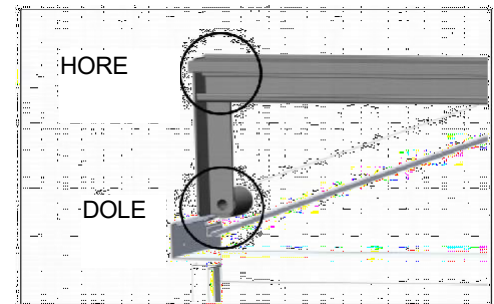

kód		Ks
L16 . 4K		1
R8		1
L15 .4K		1
Y1		3
Z3		4
Y1 0		1

# 8-1

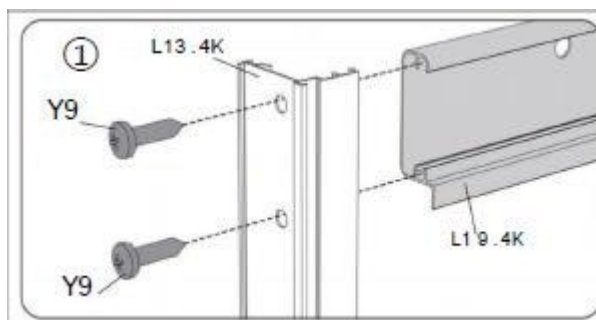
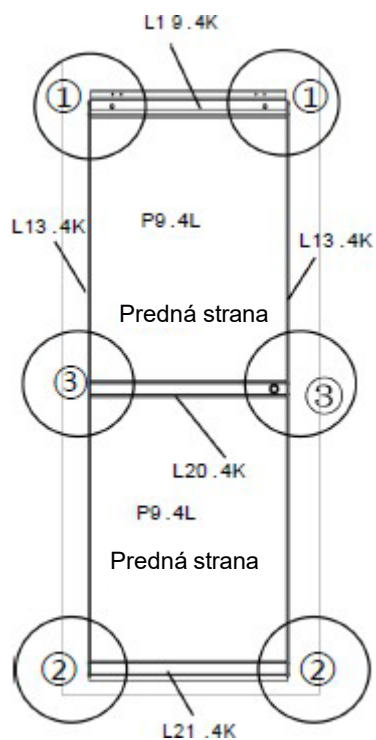

①②③

1. Umiestnite všetky diely na miesto podľa schémy.
2. Spojte oba konce L19.4K a L13.4K so skrutkami Y9, ale neťahajte.
3. Vložte polykarbonátovú dosku (P9.4L) a utiahnite skrutkami.

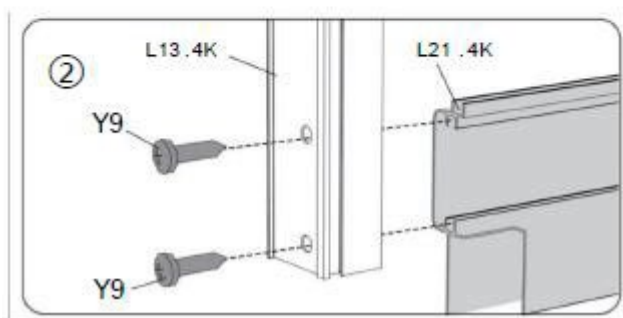
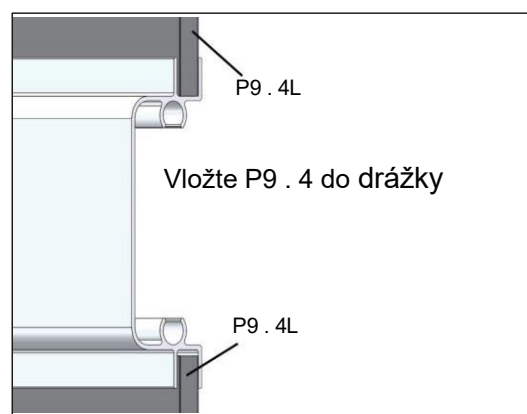
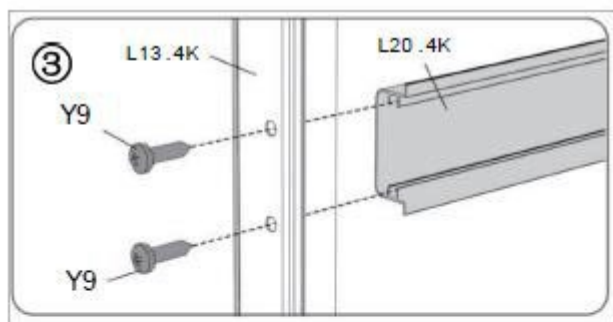

kód		Ks
L13.4K		2
L19.4K		1
L20.4K		1
L21.4K		1
Y9		12
P9.4L		2

# 8-2

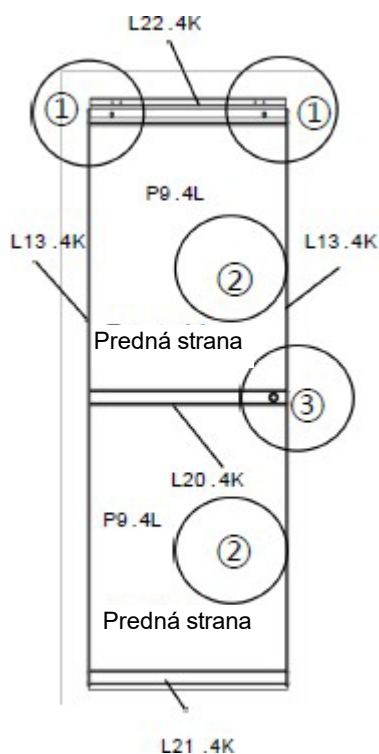

①

Tieto 3 otvory slúžia na nastavenie výšky dverí.

Tu je možné nastaviť výšku posuvných dverí.

① Pomocou skrutky Y7 pripevníte pojazd (J4) na zadnú stranu L22.4K. Potom zaistíte L22.4K k L19.4K (horný rám) pomocou skrutky a matice.

② Zaistíte polykarbonátové panely pomocou spŕn J6

③ Nainštalujte kľuku dverí podľa schémy s Y3.

kód		Ks
J6		8
J4		2
J5		4
Y3		5
Z1		4
Z2		4
Y7		4
J3		1
Y1		4
Z3		4
L22.4K		1

# 8-3

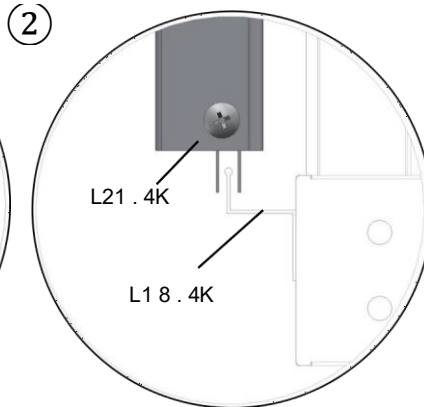
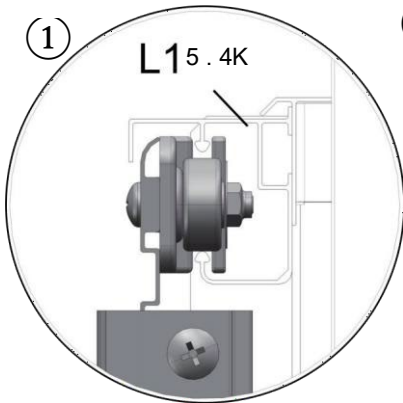
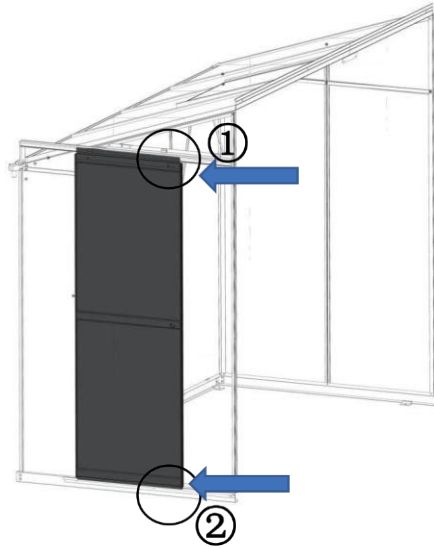

① ②  
 Nasuňte dvere do koľajnice.  
 Horné pojazdy sedia do hornej  
 vodiacej lišty – zatlačte ich úplne  
 dovnútra.  
 Spodná časť sa posúva po  
 prahovej  
 koľajnici.

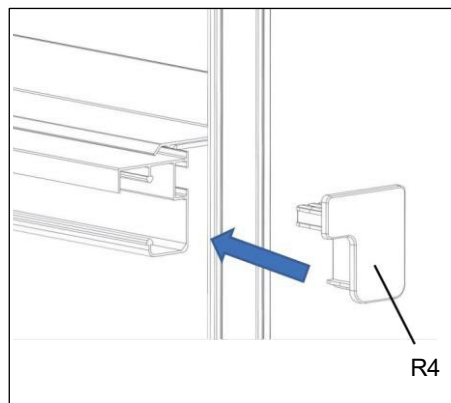
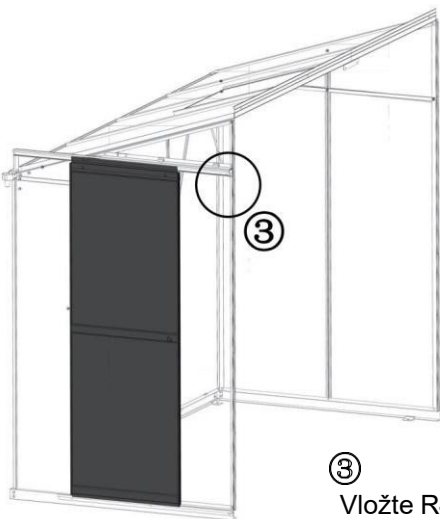

③  
 Vložte R4 pre ochranu.

kód		Ks
R4		1

# 8-1

## Pohľad na predné dvere

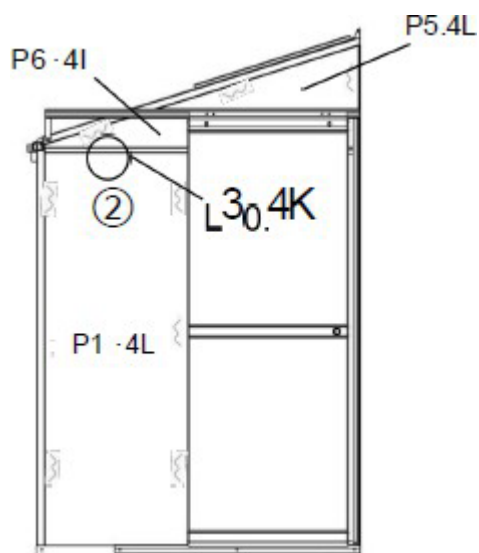

## Pohľad zozadu

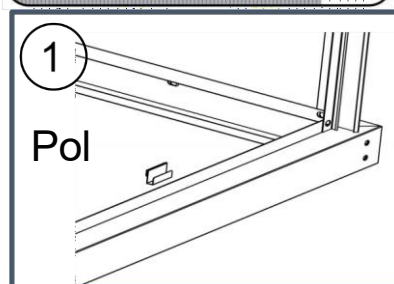
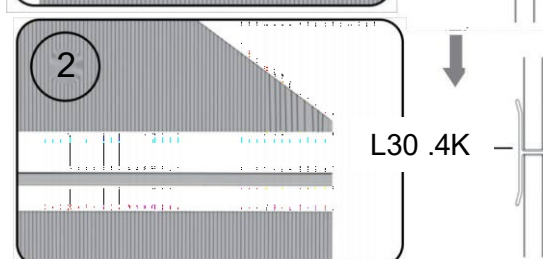
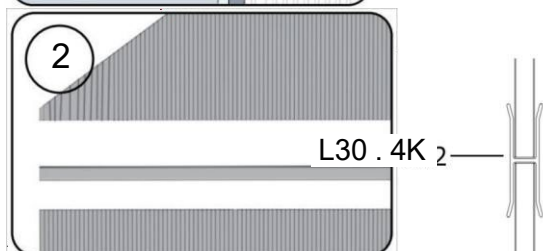
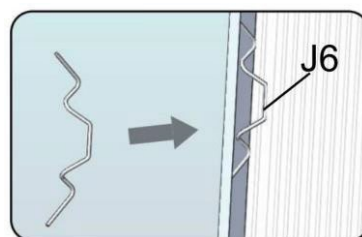
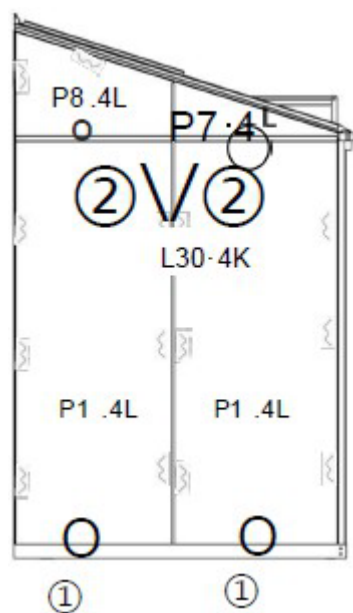

1. Pripevnite spony (R7) na základňu skleníka, aby držali polykarbonátové panely.
2. Namontujte spojovaciu lištu (L30 . 4k) medzi horný a dolný panel a potom zaistite boky pružinovými sponami (J6).

kód		Ks
P1 .4L		3
P5 .4L		1
P6 .4L		1
P7 .4L		1
P8 .4L		1
L30 .4K		3
R7		5
J6		24

# 8-2

Pohľad na strechu zhora

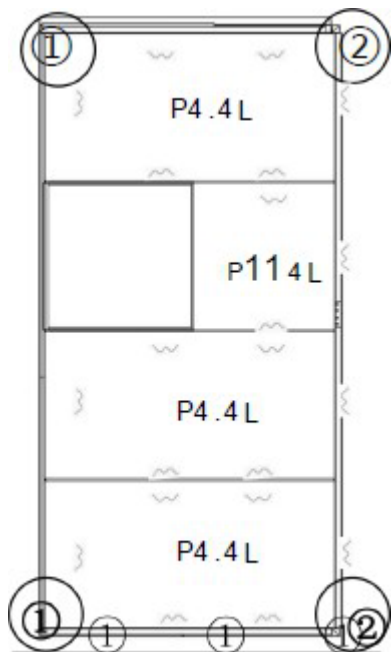

Pohľad na bočnú stenu

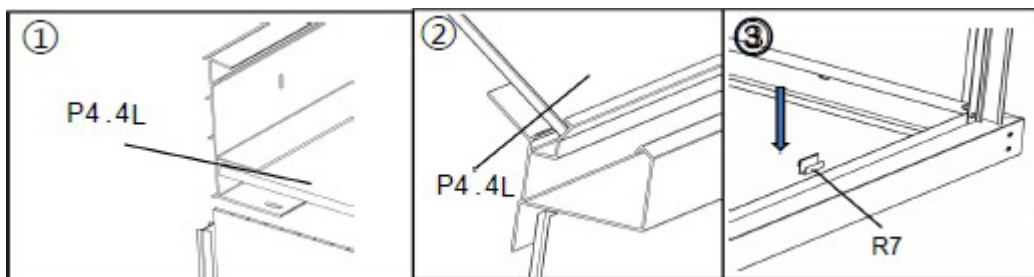
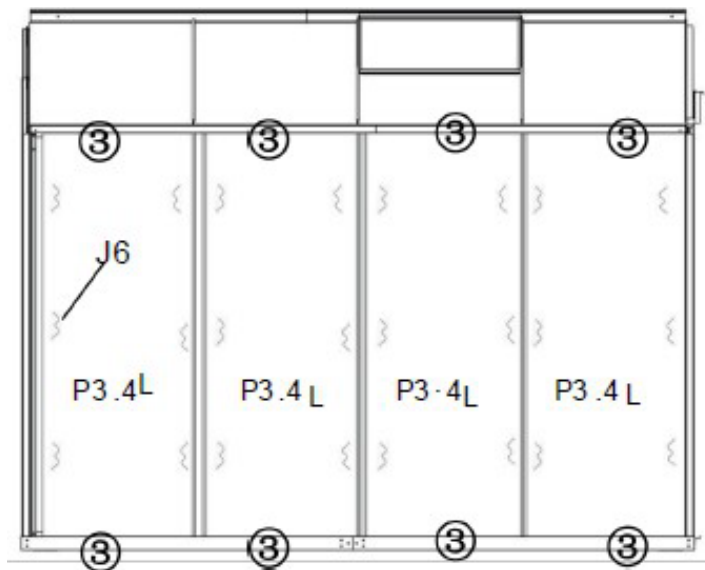

③ Pripevnite spony (R7) na horný a spodný rám, aby pevne držali polykarbonátové panely.

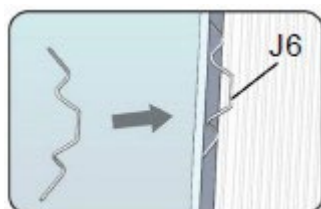

kód		Ks
P4.4L		3
P11.4L		1
P3.4L		4
R7		4
J6		45

# 9

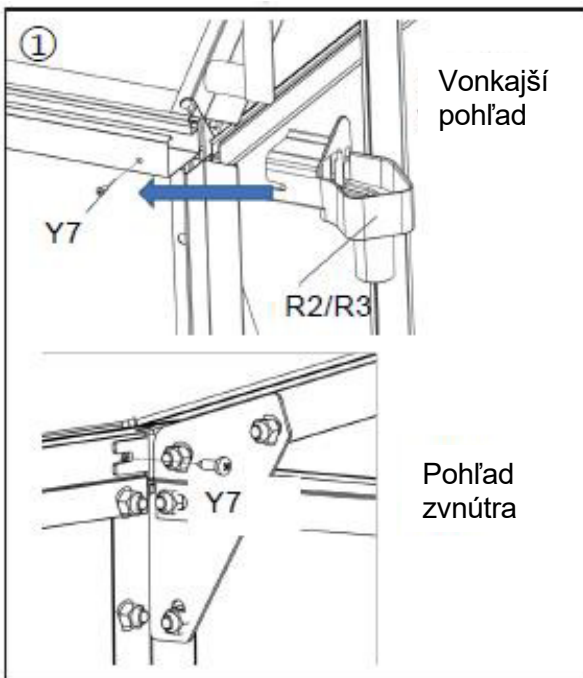
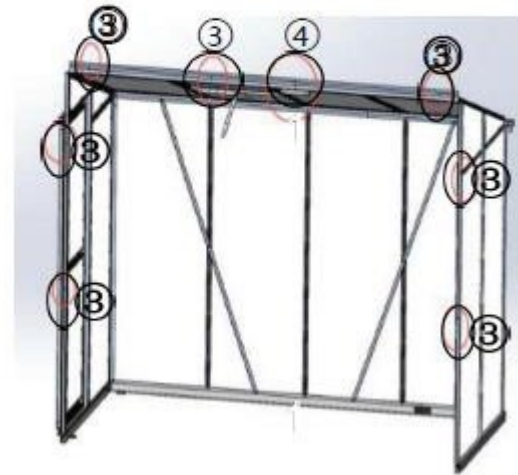
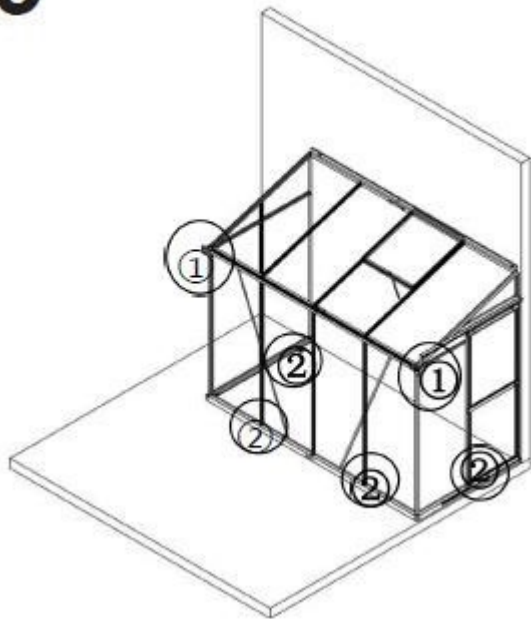

kód		Ks
R2		1
R3		1
Y7		4
Y4		4
Y1 1		9
B6 . B		4

