

VOLITEĽNÉ DIELY K BRÁNKE

NÁVOD BRANKA-PÄTKA PLOT1

F Nasuvná
matica 14x

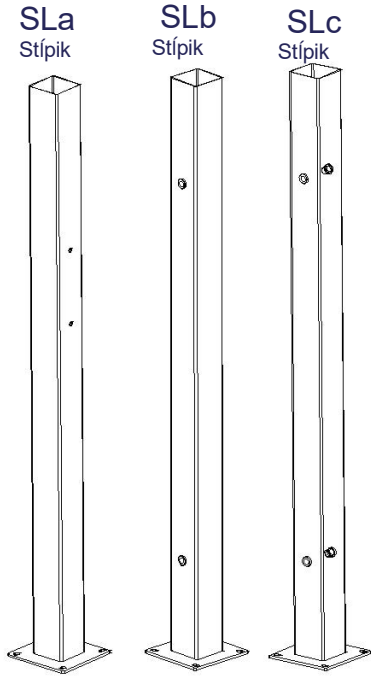
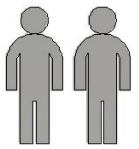

B Rám 1x

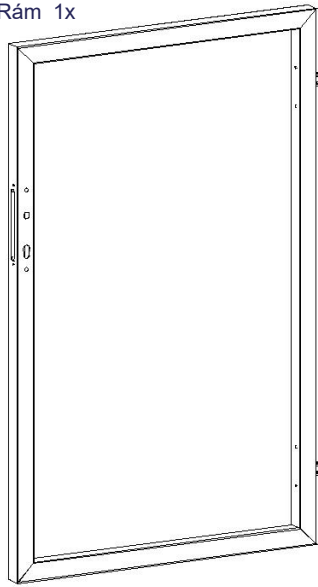

C U profil 2x



D Krycia lišta 2x



E skrutka M6x10
14x



G Plotovka 7x

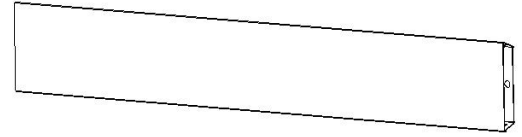

H Samovrtná skrutka s
golierom 6,3x19
4x

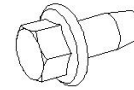

I Doraz brány
1x

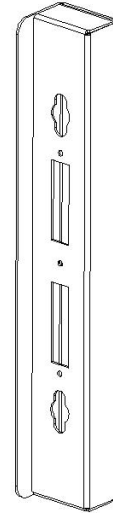

J Krytka dorazu
1x

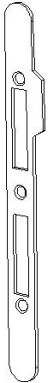

N Zámok
zadlabávací
1x

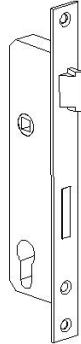

O kľučka 1x

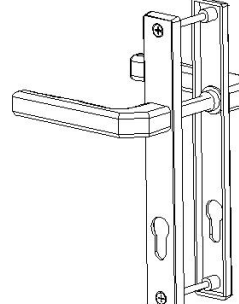

L Samovrtná skrutka
4,8x13
5x

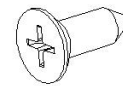

M Pánt
2x



P Krytka stĺpika
2x

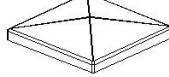

NIE JE SÚČASŤOU
BALENIA

MATICA
M12
8x

PODLOŽKA 12
8x



ZÁVITOVÁ
TYČ M12 8x

ODPORUČANÁ PRÍPRAVA NA MONTÁŽ BRANKY VENUJTE ZVÝŠENÚ POZORNOSŤ ORIENTÁCII STĽPOV

STĽPIK
PODĽA
ZVOLENÉHO
TYPU
(SLa,SLb,SLc)

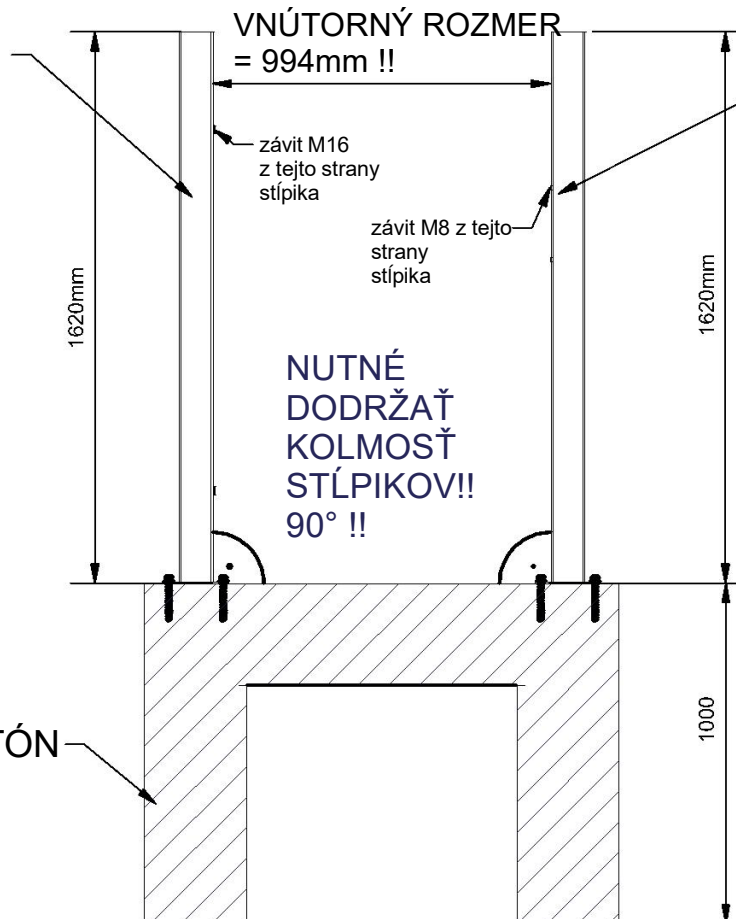

STĽPIK
PODĽA
ZVOLENÉHO
TYPU
(SLa,SLb,SLc)

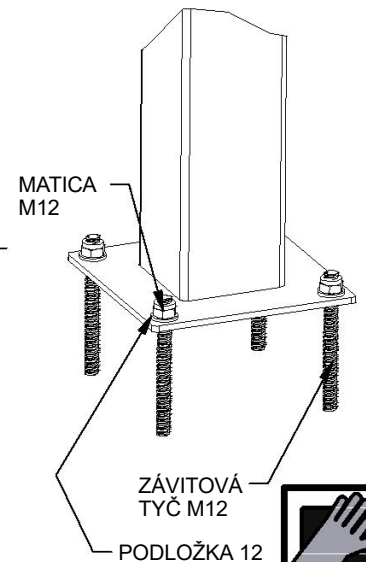

1



V PRÍPADE, ŽE BUDE V PLOTOVKE

NITOVACIA MATICA

NASUVNÚ MATICU (F)
NEPOUŽIJEME!!

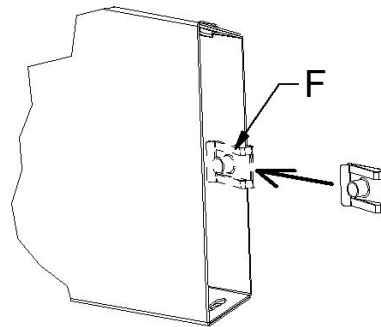
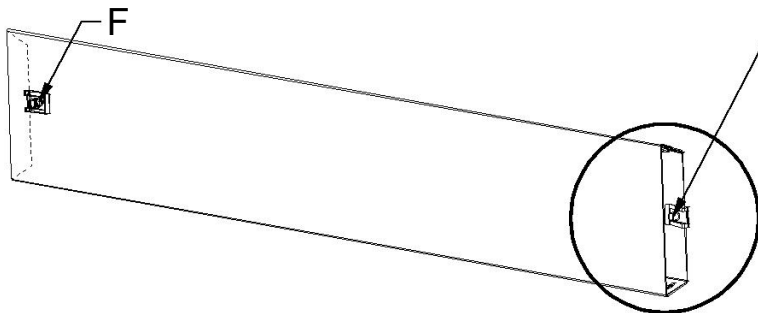
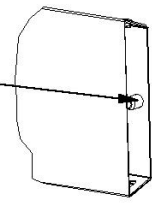

1

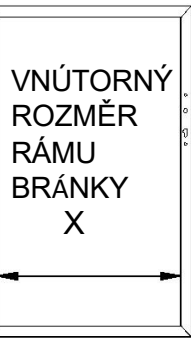

HORE otvor
Ø7 !!

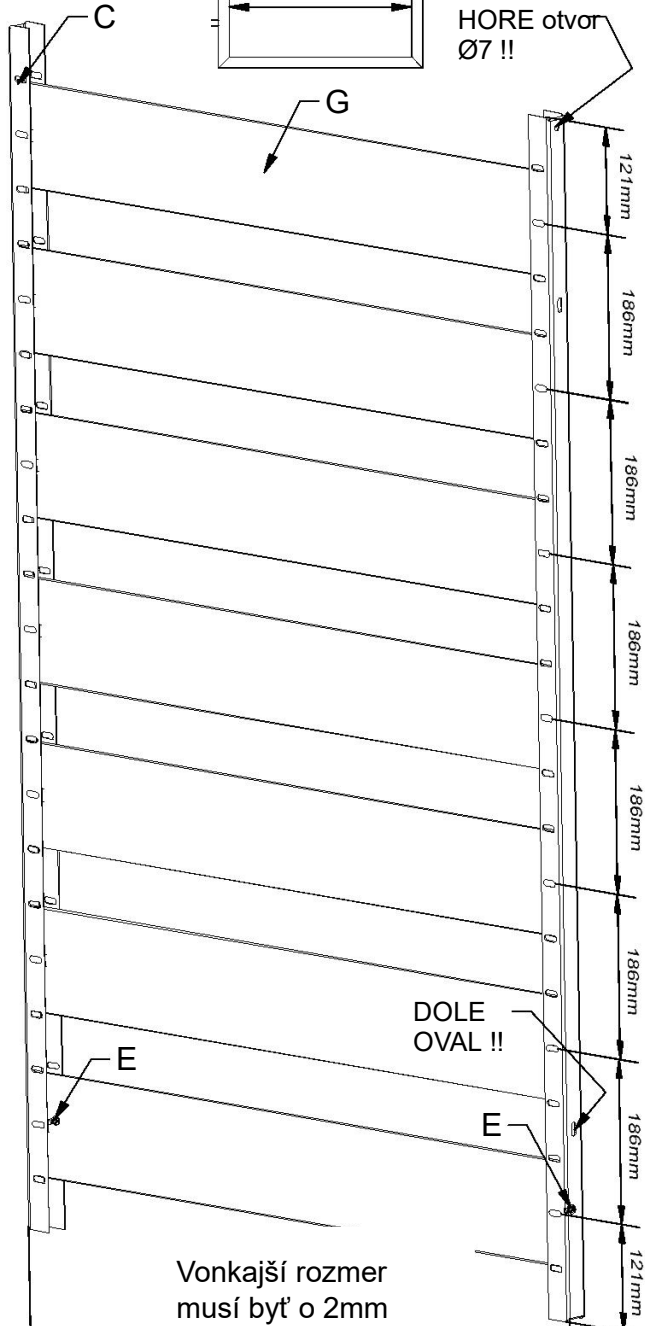

Vonkajší rozmer
musí byť o 2mm
MENŠÍ ako vnútorný
rozmer rámu brány X

2

HORE otvor
Ø7mm

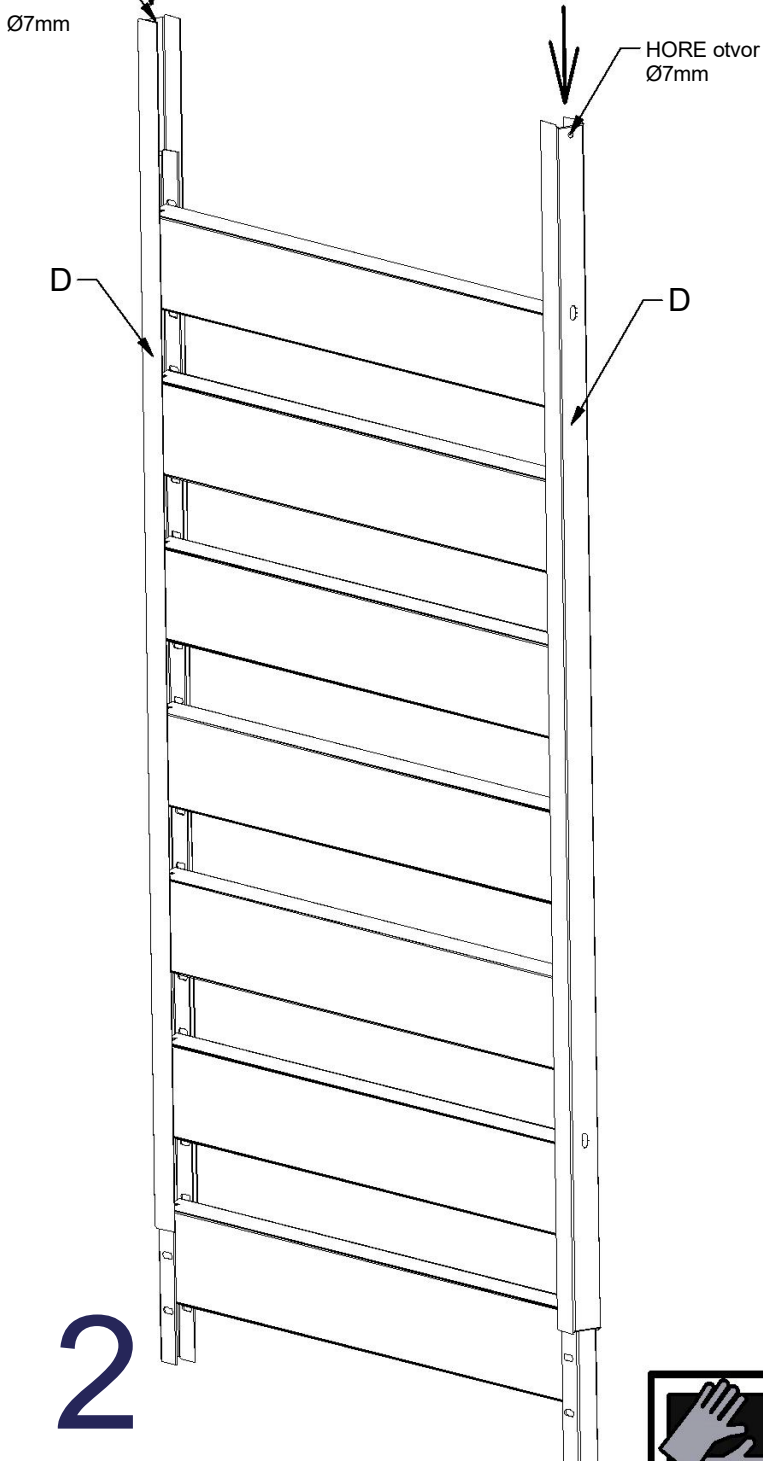

HORE otvor
Ø7mm

2



3

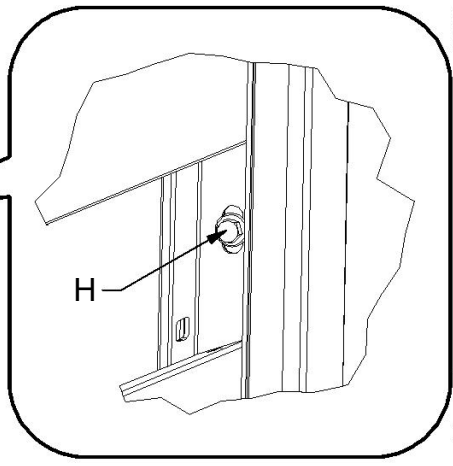
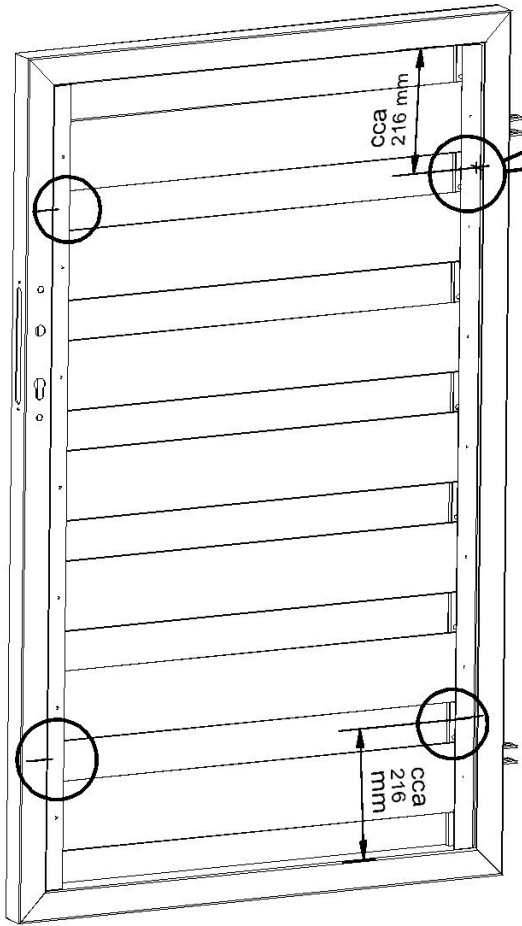

4

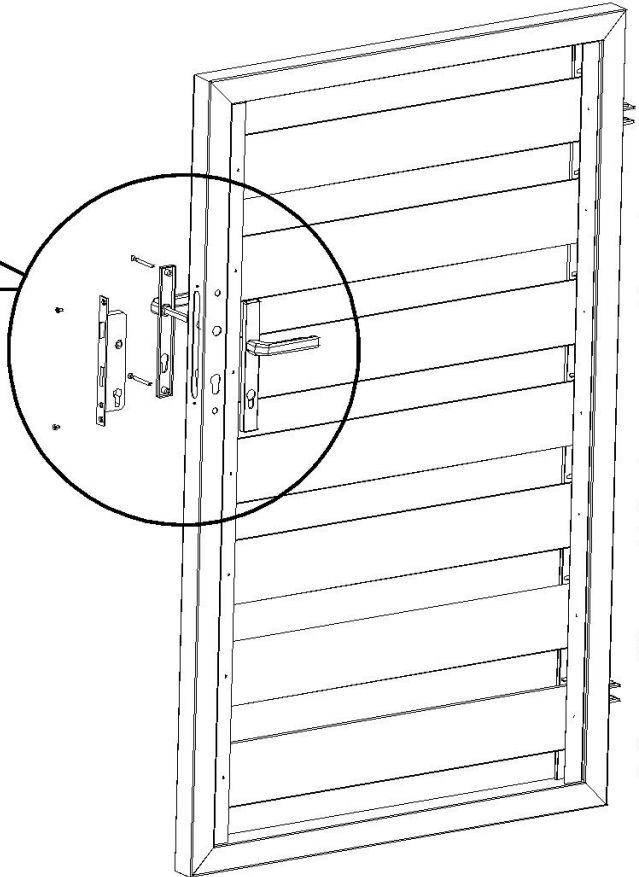
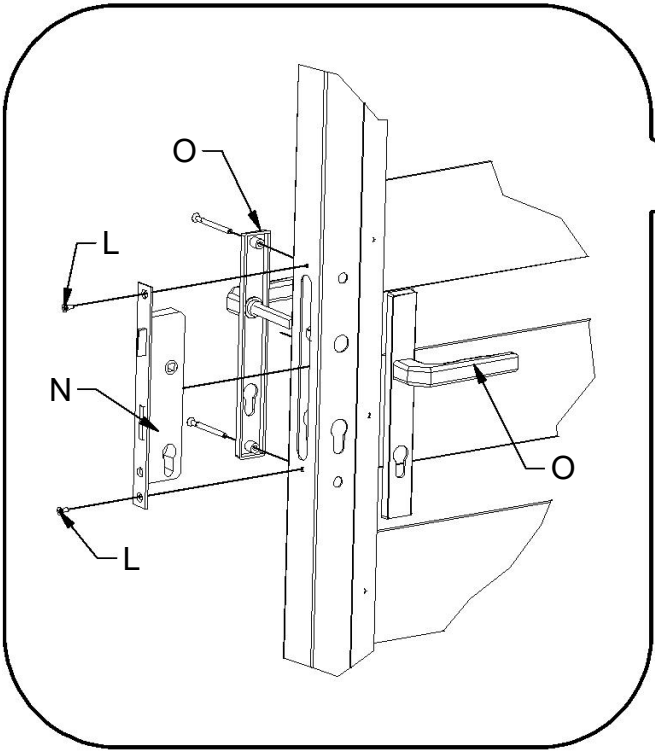

3



5

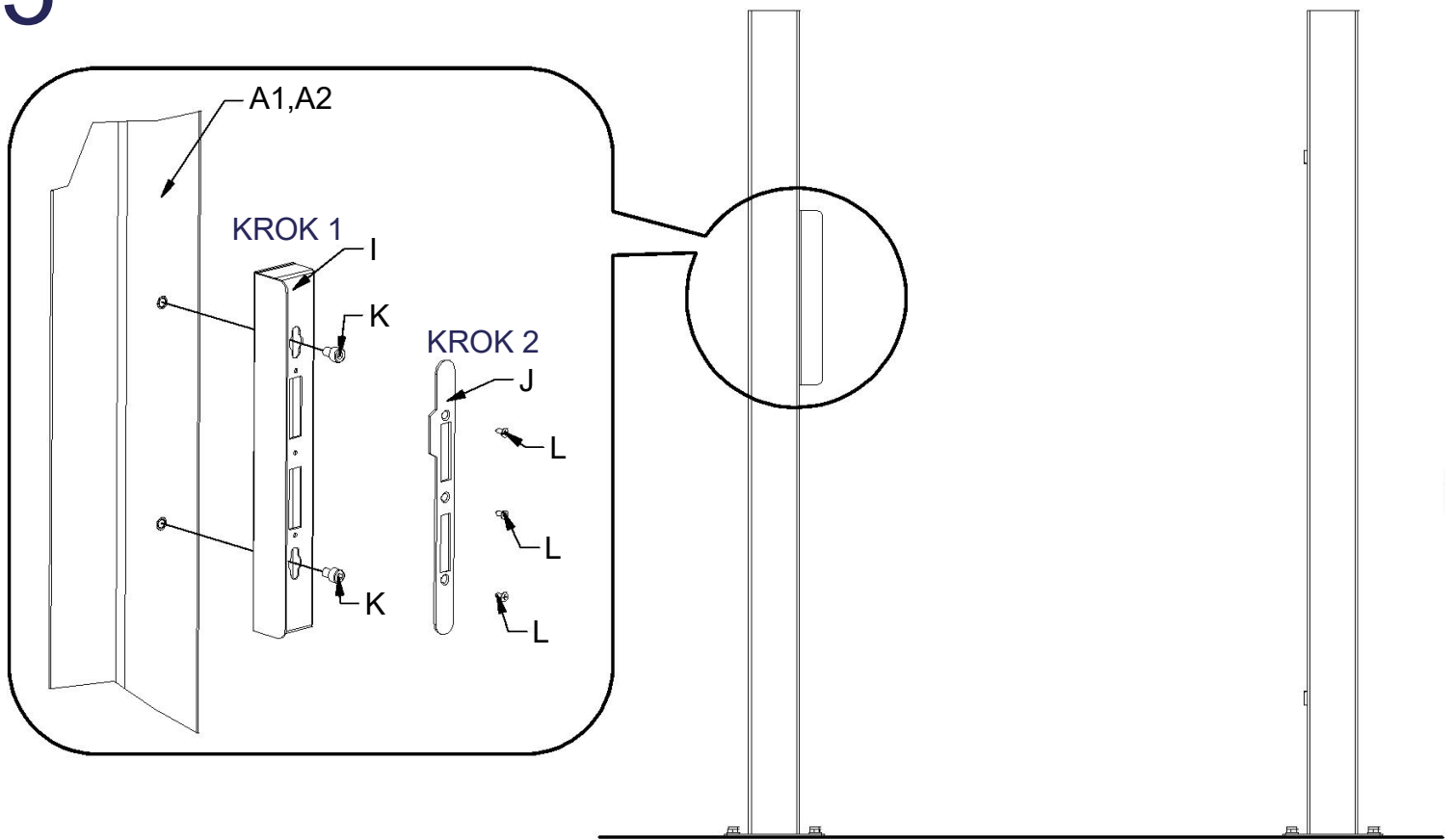

6

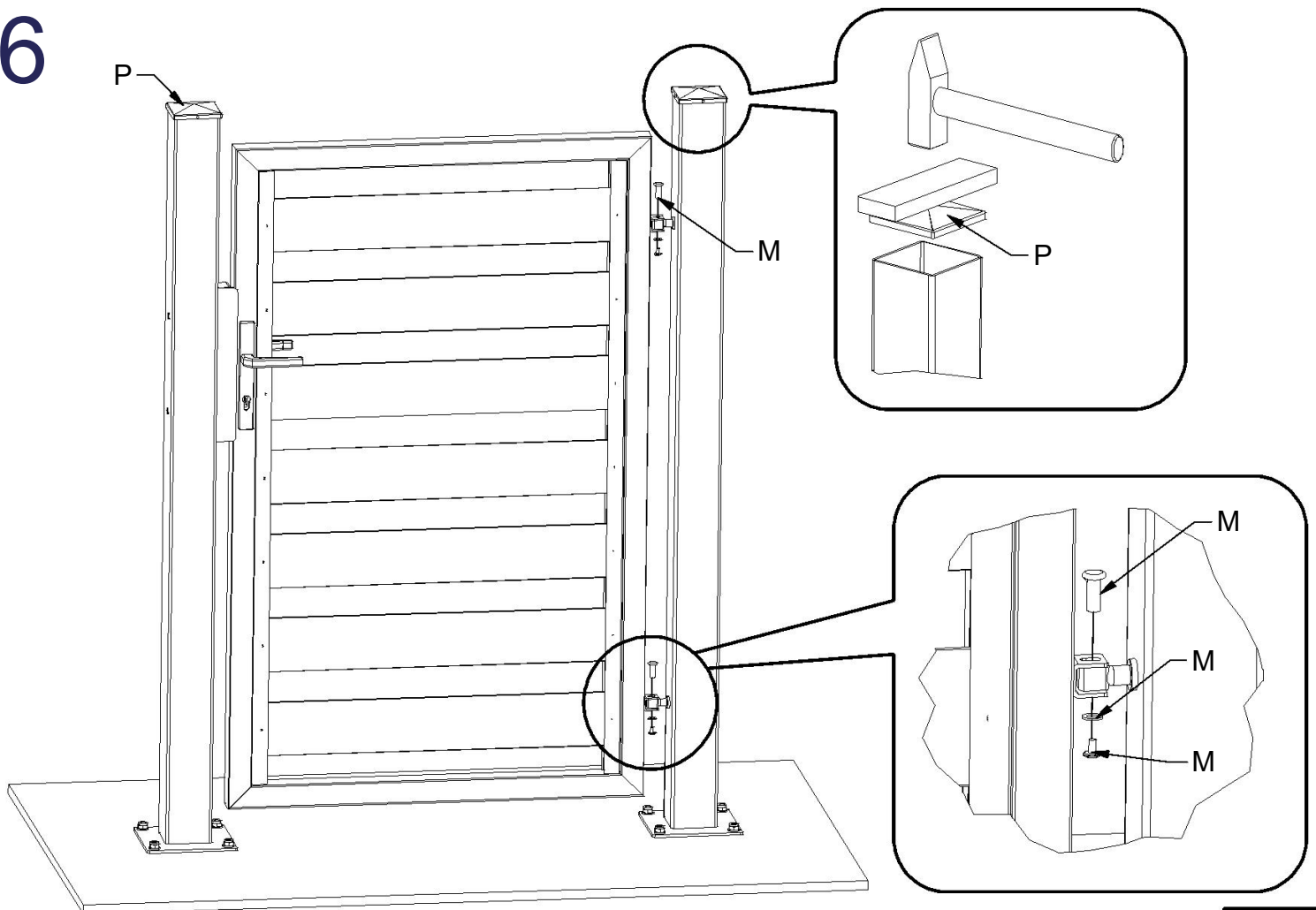

NEVYUŽITÉ OTVORY V STĹPIKOCĤ JE MOŹNÉ VYUŹIŤ AKO
PRIECHODKY ALEBO TIETO OTVORY PREKRYŤ SKRUTKOU



VOLITEĽNÉ DIELY K BRÁNKE

NÁVOD BRANKA-DO ZEME PLOT1

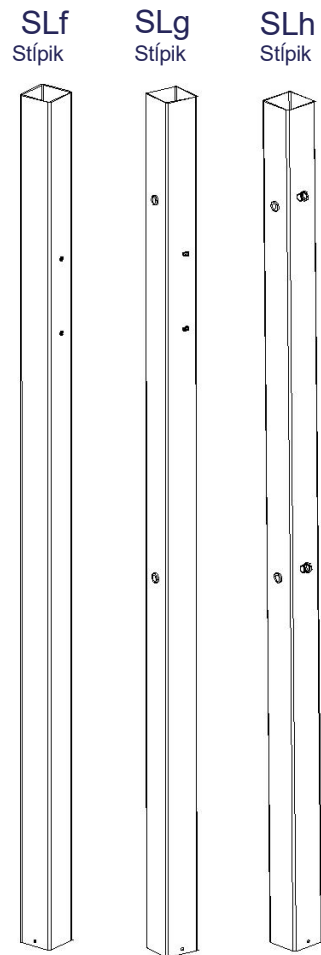
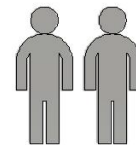

B
Rám 1x

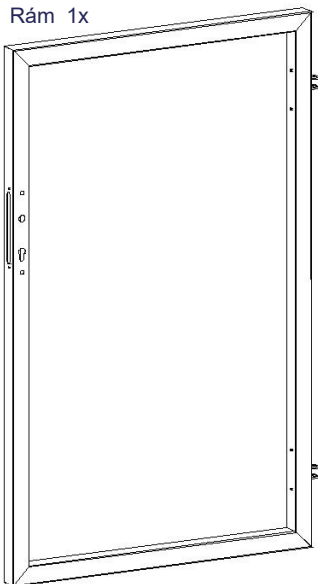

C
U profil 2x



D
Krycia lišta 2x



E
skrutka M6x10
14x



F
Nasuvná
matica 14x

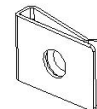

G
Plotovka 7x

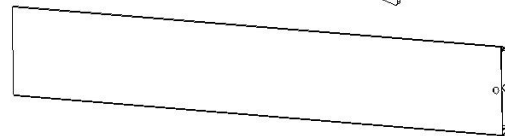

H
Samovrtná skrutka s
golierom 6,3x19
4x

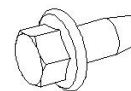

I
Doraz brány
1x

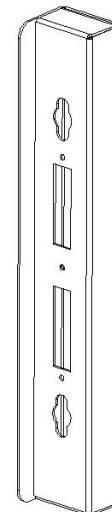

J
Krytka dorazu
1x



M
Pánt
2x



N
Zámok
zadlabávací
1x

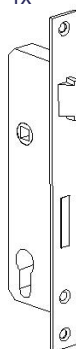

O
kľučka 1x

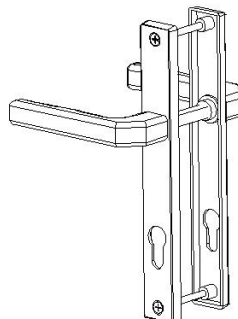

L
Samovrtná skrutka
4,8x13
5x

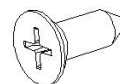

P
Krytka stĺpika
2x

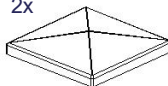

K
Skrutka M8x12
2x



ODPORUČANÁ PRÍPRAVA NA MONTÁŽ BRANKY VENUJTE ZVÝŠENÚ POZORNOSŤ ORIENTÁCII STĽPOV

STĽPIK
PODĽA
ZVOLENÉHO
TYPU
(SLf,SLg,SLh)

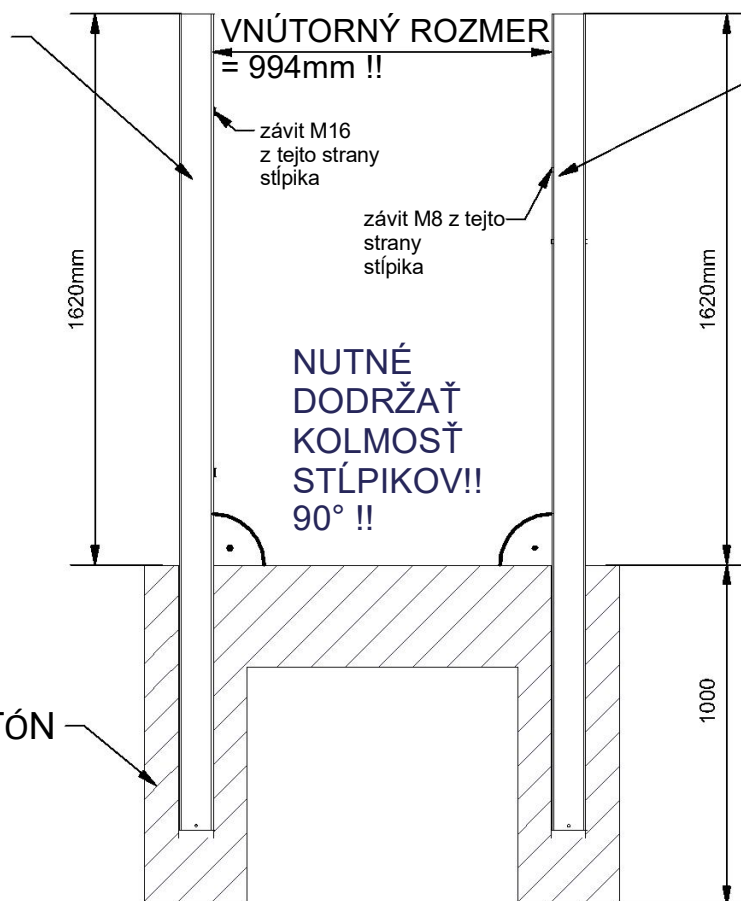

STĽPIK
PODĽA
ZVOLENÉHO
TYPU
(SLf,SLg,SLh)

1



V PRÍPADE, ŽE BUDE V PLOTOVKE

NITOVACIA MATICA

NASUVNÚ MATICU (F)
NEPOUŽIJEME !!

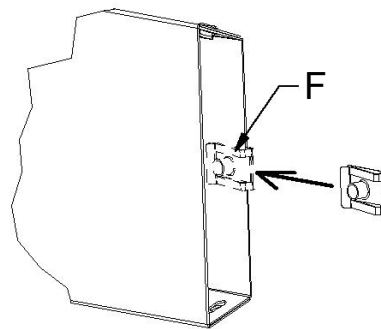
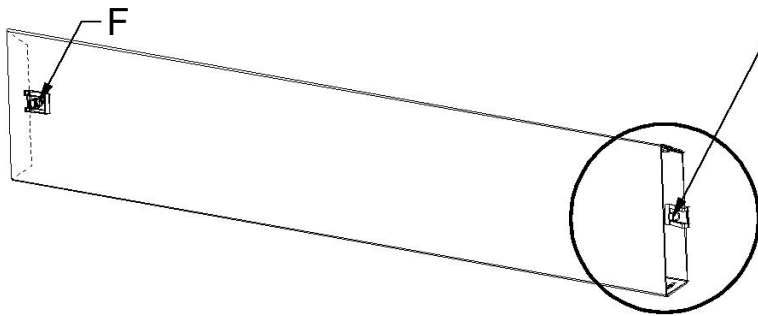
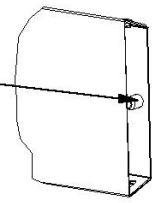

1

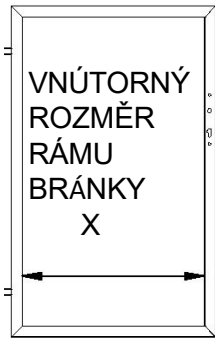

HORE otvor
Ø7 !!

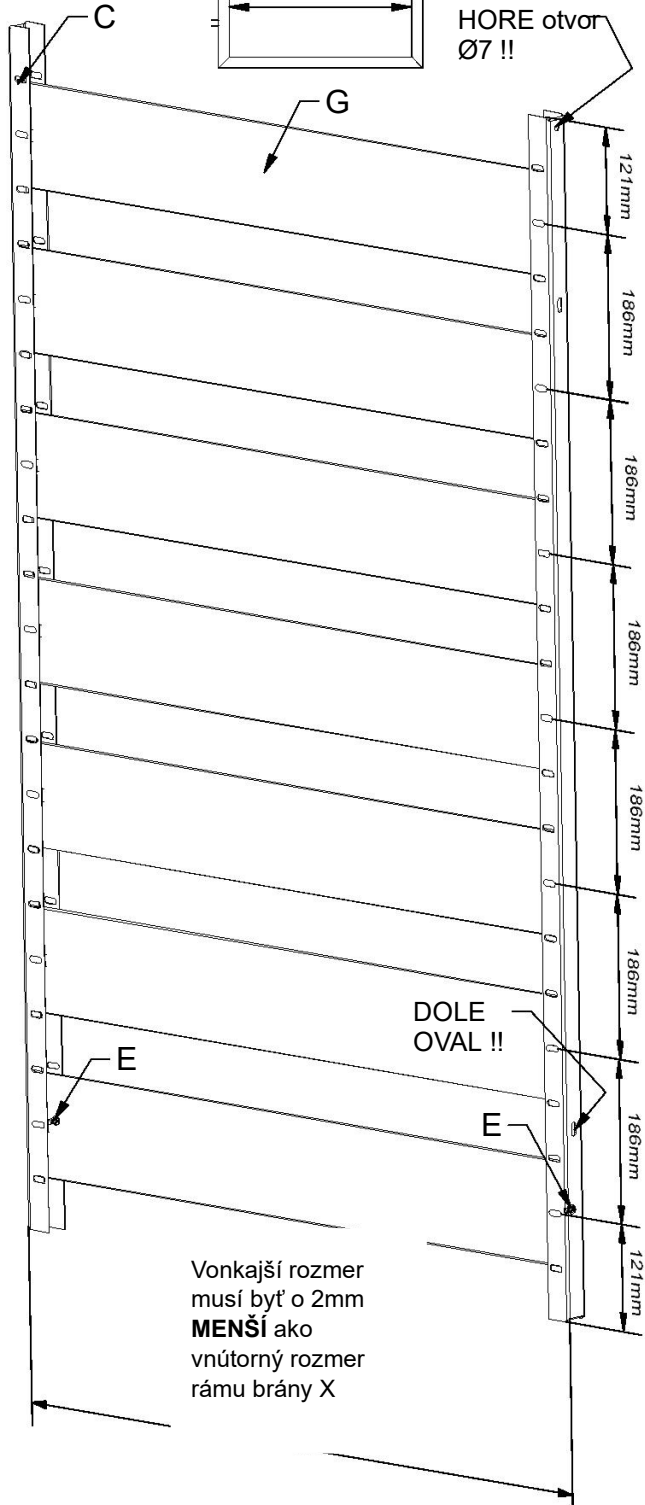

DOLE
OVAL !!

Vonkajší rozmer
musí byť o 2mm
MENŠÍ ako
vnútorný rozmer
rámu brány X

2

HORE otvor
Ø7mm

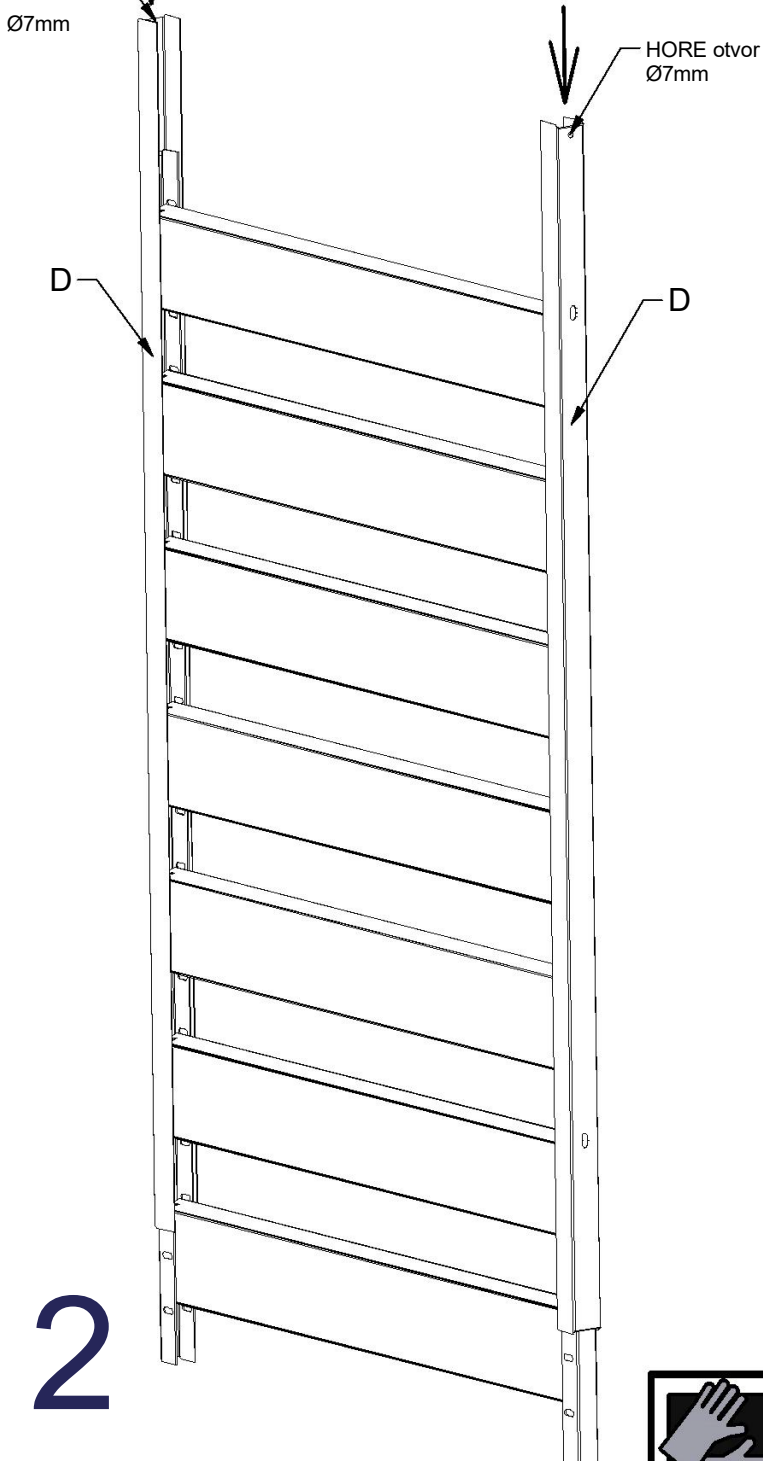

2



3

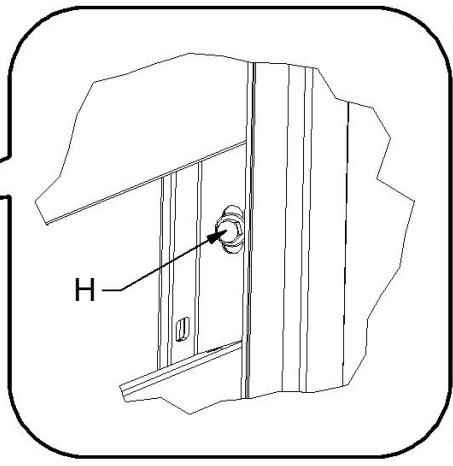
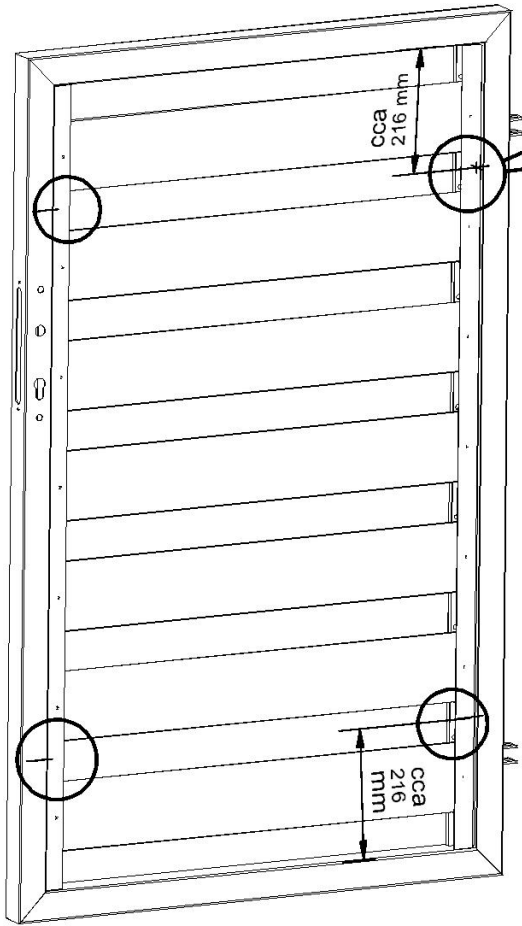

4

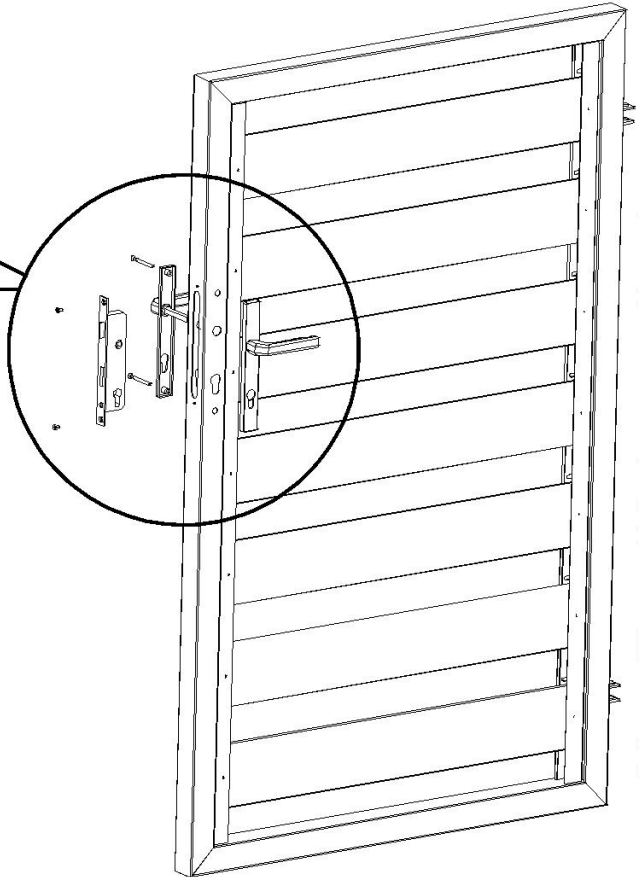
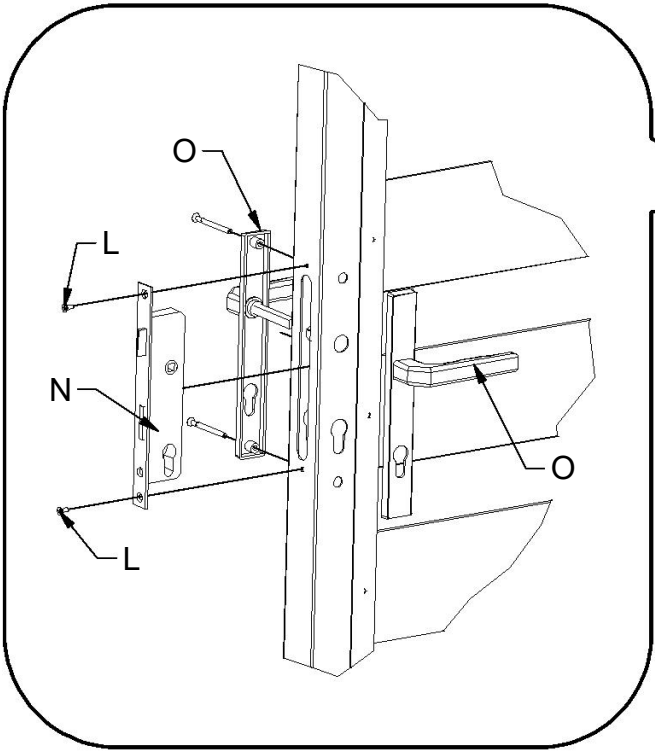

3



5

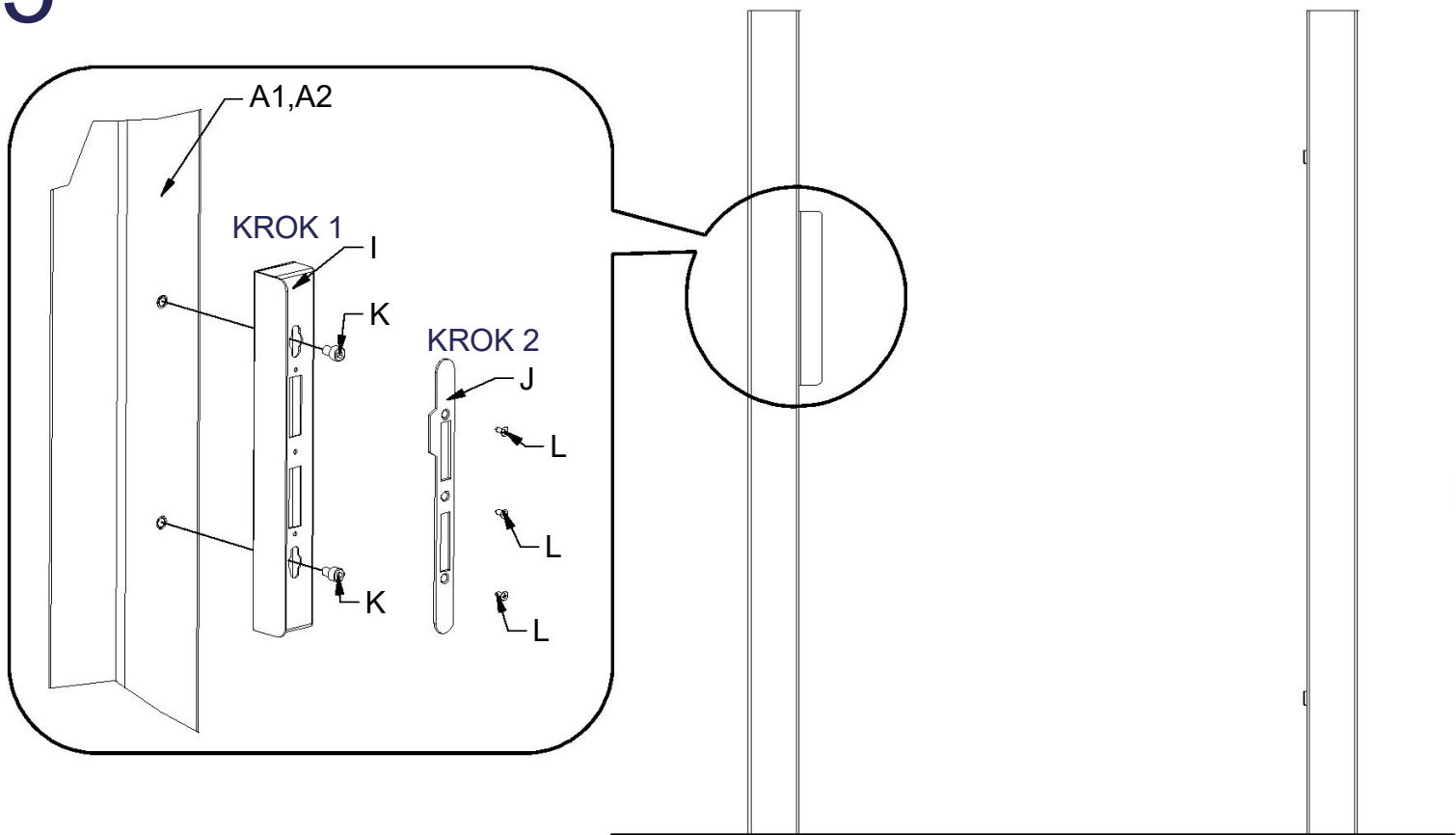

6

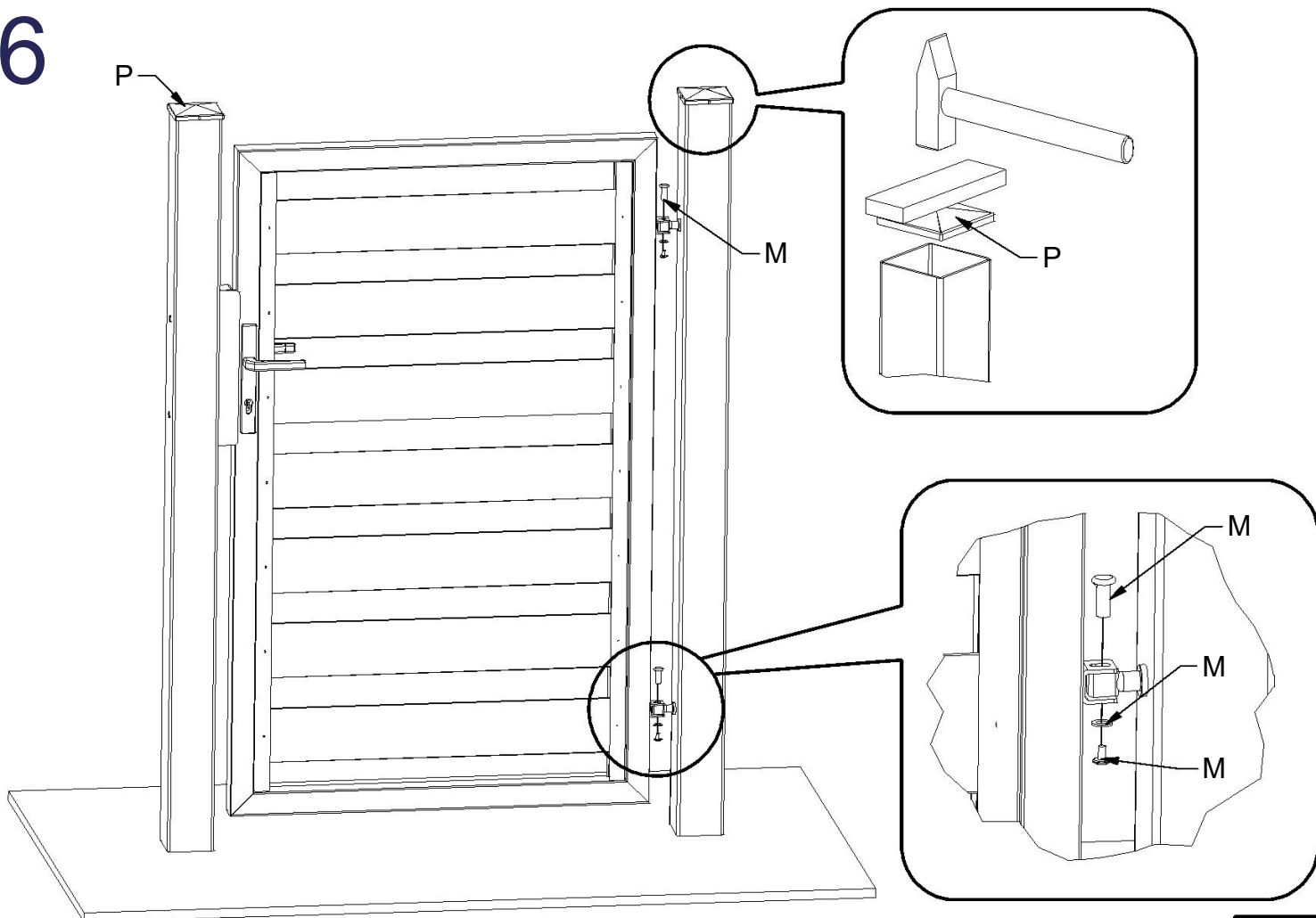

NEVYUŽITÉ OTVORY V STĽPIKOCĤ JE MOŽNÉ VYUŽIŤ AKO PRIECHODKY ALEBO TIETO OTVORY PREKRYŤ SKRUTKOU



RADY A TIPY

TIP PRE PRESNÉ NASTAVENIE STĽPIKA S PÄTKOU DO ROVINY POMOCOU MATICE M12 POD PÄTKOU STĽPIKA

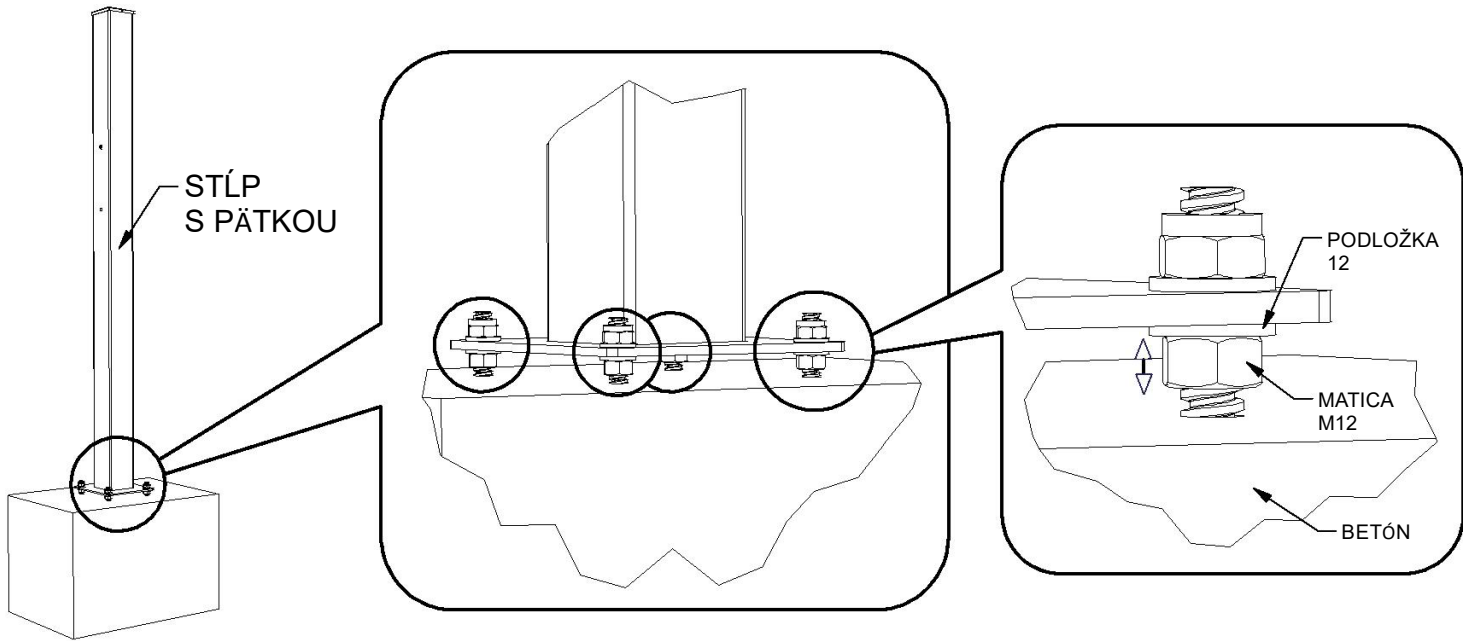

TIP PRE MONTÁŽ PLOTOVÉHO POĽA DO RÁMU BRÁNKY, BRÁN, POJAZDOVEJ BRÁNY

1. Podložky 8 vložíme medzi rám a U profily a pripojíme samovrtnou skrutkou 2.

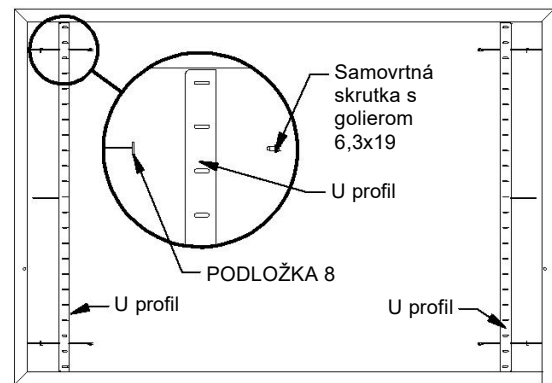

K U profilom primontujeme plotovky

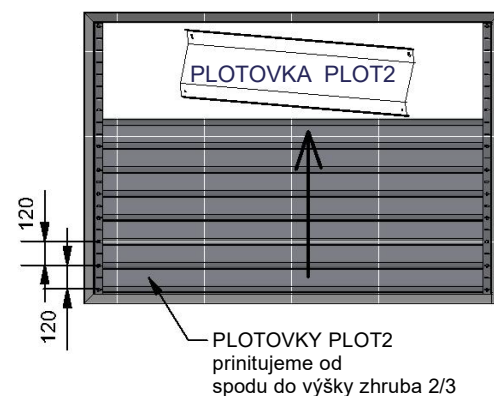
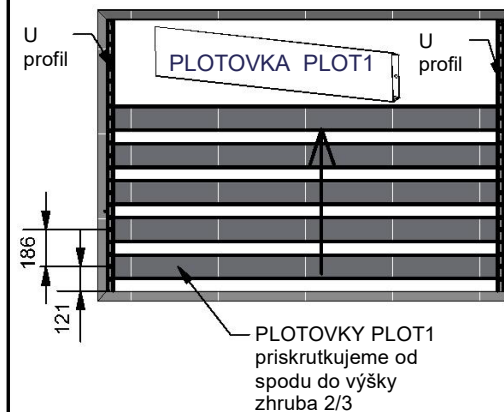

3. Plotové pole zdemontujeme od rámov tak, že odskrutkujeme samovrtné skrutky a potom dodáme zostávajúce plotovky

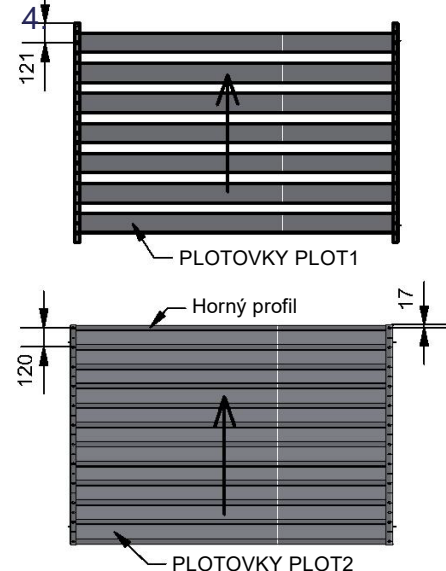

Nasunieme Krycie lišty

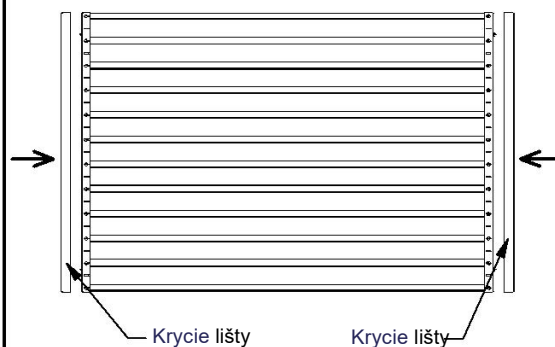

5. Kompletné plotové pole vložíme opäť do rámu a zaistíme ho samovrtnými skrutkami

